

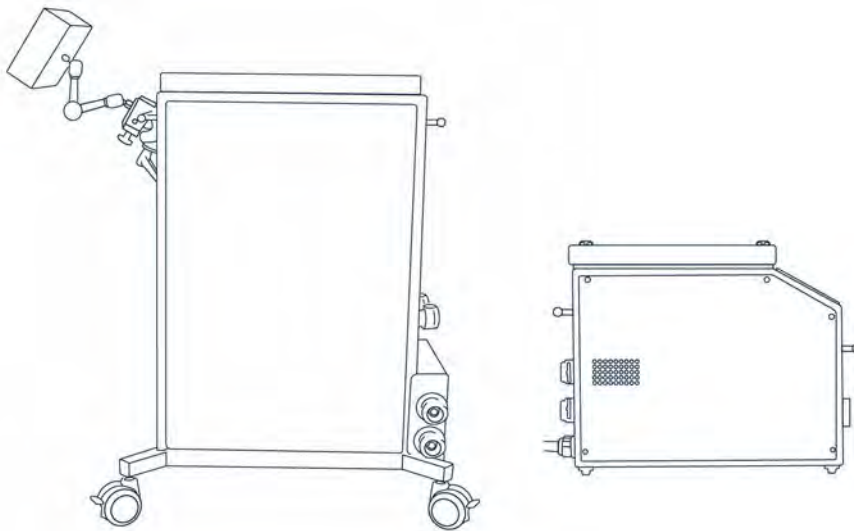

Model MCH-1000

Operator/Service Manual

Cardiopulmonary Bypass Temperature Controller



Publication Date: January 26, 2024

LBL-01 Ver. 7

Document Change Tracking

Date	Change	By	Approval
4/8/09	Original version	JLG	DEP
5/4/10	Added disposal procedures for standards compliance	JLG	DEP
3/21/12	Updated to R2, added MCH-1000(m) information	JLG	DEP
3/27/14	Added Cardioplegia Shared Channel (CSC) Module information	JLG	DEP
8/1/14	Updated maintenance procedures	JLG	DEP
11/4/14	Added Thermo-Electric Cooling (TEC) Module information	JLG	DEP
6/15/15	Added part number and revision	JLG	DEP
6/24/15	IEC 60601-1 compliance-related edits	JLG	DEP
9/3/15	Added necessary warnings/cautions for EMC compliance Added Refrigeration Module information Corrected leakage current specification	JLG	DEP
2/17/16	Improved & expanded cleaning procedures for clarity Added patient blanket section Other IEC 60601-1-2:2014 compliance updates	JLG	DEP
5/5/16	Added additional information on Refrigeration Module & hose kits Improved overall document formatting Updated indications for use, alarm sound pressure range specification, disinfectant information (added residual levels) Added airflow-related cautions & specifications	JLG	DEP
9/28/16	Fixed discrepancy in bleach concentration specifications	JLG	DEP
11/30/16	Updated warranty text	JLG	DEP
7/6/2021	Regulatory edits, updated water quality requirements, formatting changes to improve legibility	WO	DEP
5/23/2022	Removed discontinued product images	WO	DEP
11/21/2022	Fixed formatting, specification, and instruction errors and updated verbiage for items such as water usage and cleaning/disinfection. Added text to provide greater clarity for items such as expected service life.	WO	DEP
1/26/2024	Device Labeling Table edited to reflect changes in product labeling.	WO	DEP

Notices

The information in this document may change without notice. CardioQuip makes no warranty of any kind regarding this material including, but not limited to, the implied warranty of merchantability and fitness for a particular purpose. CardioQuip cannot be held liable for errors herein or for consequential damages concerning the use of this material.

CardioQuip reserves the right to make equipment changes and improvements which may not be reflected in this manual. Online support resources, including the latest version of this manual, may be accessed at <https://www.cardioquip.com/resources>.

This document may not be reproduced in whole or in part, as it contains proprietary information. Such information may not be disclosed to others for any purpose or used for manufacturing purposes without written permission from CardioQuip. Reproduction or storage of this material in electronic media without the express written permission of CardioQuip is prohibited.

Manufacturer's Responsibility

CardioQuip may consider itself responsible for any effect on the safety, reliability and performance of the equipment if and only if:

- Repairs, adjustments, modifications or retrofit are performed by authorized CardioQuip service personnel
- The device is used according to the instructions set forth in this manual
- The electrical service and connections comply with relevant electrical codes

For assistance, call **888-267-6700** (in the U.S.) or **+1 979-691-0202** (international).

© Copyright 2022 CardioQuip, LLC. All rights reserved.

Table of Contents

General Information.....	4
Introduction	4
Indications for Use	4
Expected Service Life	4
Manual Conventions	4
Warnings and Precautions	5
Device Labeling	8
Specifications	9
Obtaining Service	11
Service Contact Information.....	11
Limited Warranty	12
Storage	13
Transportation.....	13
Lifting.....	13
Overview.....	14
MCH-1000 Hardware Overview	14
Optional Module Hardware Overview	15
Operation Overview.....	16
Unpacking.....	16
Control Screens	18
Power-on	18
Water Level	18
System Test.....	19
Standby	20
Priming.....	21
Settings	22
Defrost	23
Run.....	23
Run Lock.....	24
Cardioplegia Shared Channel.....	25
Alarms.....	26
Low Water Level (medium priority).....	26
Low Ice (low priority).....	26
Overtemp (medium priority).....	27
Temperature Differential (medium priority).....	27
System Failure (medium priority).....	28
Audio Silence	28
Setting the Temperature: 3 Ways.....	29
Tenth-Degree Adjustment.....	29
Manual Input	29
Presets	29
Connectors, Valves, & Hoses.....	30
Main Hose Connectors	30

Cardioplegia Hose Connectors.....	31
Internal Recirculation Valve.....	31
Blanket Hose Connectors.....	32
System Drain	33
Tank Drain	33
Hose Kits.....	34
Standard Hose Kit.....	34
Dripless Hose Kit.....	34
Optional Hose Kits with Blanket Adapters.....	34
Tank Lid Anchor Knobs	35
Patient Blankets.....	36
Blanket Orientation.....	37
Optional Cooling Modules.....	38
Thermo-Electric Cooling (TEC) Module.....	38
TEC Module Installation	38
TEC Module Operation.....	38
TEC Module Maintenance	38
TEC Module Storage.....	38
Refrigeration Module.....	40
Refrigeration Module Installation.....	40
Refrigeration Module Operation	40
Refrigeration Module Maintenance.....	41
Refrigeration Module Storage	41
Refrigeration Module Lifting Instructions.....	42
Turbonozzle for Refrigeration Module.....	42
Airflow Redirection Hood Installation and Maintenance	43
MCH Operation.....	45
Physical Inspection.....	45
Initial Operation Check.....	45
MCH-1000(i) Control Module Check.....	47
MCH-1000 Basic Function Test.....	47
Refrigeration Module Basic Function Test.....	48
TEC Module Basic Function Test.....	48
Temperature Control System Test.....	49
Alarm Tests.....	49
Terminating Operation	50
Current Test	50
Initial Cleaning and Disinfection.....	50
Normal Operation	51
Overtemp	53
A Note About Flow	54
Maintenance.....	55
Water Quality.....	55
Cleaners & Disinfectants	55
After Every Use.....	56
Weekly Maintenance Procedure.....	57
Quarterly Maintenance Procedure.....	58
Annual Maintenance.....	60
Replacing External Tubing.....	60
Disposal Procedures.....	60
Troubleshooting.....	61

GENERAL INFORMATION

Introduction

The CardioQuip Modular Cooler-Heater (MCH) brings easy and accurate temperature control to the operating room. The latest touchscreen technology offers fast, user-friendly, multi-language device control. Redundant software and hardware failsafes ensure patient safety. A combination of audible and visual alerts enable effective monitoring without undue distraction. Conscientious design declutters the perfusionist's work area to allow more workspace. Thanks to intelligent features such as self priming, automatic defrost, and patented **Adaptive Temperature Control** technology, the MCH requires significantly less operator intervention than traditional cooler-heaters, giving the perfusionist more time for patient care.

Indications for Use



The CardioQuip Modular Cooler-Heater (MCH) is indicated to supply temperature-controlled water to heat exchange devices (e.g.; Cardiopulmonary Bypass Heat Exchangers) to help control a patient's temperature during extracorporeal circulatory support and/or thermal regulation procedures lasting not longer than six hours.

The MCH is intended to be operated by, or under the supervision of, a qualified perfusionist. This device is not designed, sold or intended for use except as indicated. While there are no known contraindications, use of the MCH for purposes other than those indicated places responsibility for performance and results with the user.

Expected Service Life

Expected Service Life (ESL) of the CardioQuip MCH-1000 comes from IEC 60601-1 and is stated to be the time period specified by CardioQuip during which the MCH-1000 is expected to remain safe for use (i.e. maintain basic safety and essential performance). When properly maintained and operated according to these instructions for use, the MCH-1000 should provide ten years of reliable service in a typical hospital environment. Once a device reaches the Expected Service Life, CardioQuip will no longer service or sell parts for the device.

Manual Conventions

This Operator's Manual uses the international alert symbol  to indicate critical safety and operational information. The alert symbol followed by a WARNING denotes an instruction or procedure which, if not carried out correctly, may result in injury to the technician, the patient or other personnel. The alert symbol followed by a CAUTION denotes an instruction or procedure which, if not carried out correctly, may damage the MCH or connected equipment. The water symbol  indicates sterile water or water that has been passed through a filter of less than or equal to 0.22-microns.

Warnings and Precautions



WARNING: Use only sterile water or water that has been passed through a filter of less than or equal to 0.22-microns. DO NOT use unfiltered tap water to rinse, fill, refill, or top-off the water tank.



WARNING: Use only ice made from sterile water or water that has been passed through a filter of less than or equal to 0.22-microns.

WARNING: If water in the water tank appears discolored, emits a foul smell, or shows visual signs of biofilm, the device must be immediately removed from use. Contact CardioQuip Customer Service for details regarding servicing assistance.

WARNING: If the external tubing appears cloudy or discolored, immediately remove the device from service and contact CardioQuip Customer Service for details regarding servicing assistance.

WARNING: Do NOT move modules or accessories between cooler-heater devices to prevent possible cross-contamination.

WARNING: To avoid the risk of electrical shock, this equipment must only be connected to a supply mains with protective earth.

WARNING: Use of this equipment adjacent to or stacked with other equipment should be avoided because it could result in improper operation. If such use is necessary, this equipment and the other equipment should be observed to verify that they are operating normally.

WARNING: Portable RF communications equipment (including peripherals such as antenna cables and external antennas) should be used no closer than 30 cm (12 inches) to any part of the MCH. Otherwise, degradation of the performance of this equipment could result.

WARNING: Explosion Hazard. Do not use in the presence of flammable anesthetics.

















WARNING: Electric Shock Hazard. Access panels should be removed only by qualified service personnel.

WARNING: The MCH is not fully automatic. Monitoring of patient temperature and rate of temperature change remains the responsibility of the operator.

WARNING: If the unit is in an over-temperature condition and the emergency cool system is used, it is crucial that the operator monitor the output water temperature.

WARNING: It is the operator's responsibility to use and maintain this device according to the labels of the product, accompanying instruction manuals, and any revisions of the labeling or instructions that may be subsequently issued.

WARNING: Proper surgical procedures and techniques are the responsibility of the operator.

-  **WARNING: Servicing of this unit shall be performed by authorized CardioQuip technicians only.** Improper repair can result in patient injury and/or damage to the system.
-  **WARNING: This device must not be connected to a heat exchanger or blanket with a manufacturer recommended maximum pressure rating of less than 83 kPa (<12 psi).** Rupture or leakage may occur in the heat exchanger, resulting in patient injury and/or damage to the system.
-  **WARNING: The MCH must be properly cleaned and disinfected prior to operation or storage** to prevent high microbial count or residual chemicals that could cause equipment damage.
-  **WARNING: During clinical operations, do not drain equipment connected to the MCH.** Draining attached equipment will drain the entire heat exchanger network.
-  **WARNING: U.S. law restricts this device for sale to, or use by or on the order of, a licensed physician.**
-  **WARNING: Do not perform reprocessing procedures in operating or patient rooms.**
-  **CAUTION: Read this complete Operator's Manual before using this device.**
-  **CAUTION: No modification of this equipment is allowed.**
-  **CAUTION: Use a dedicated 20 Ampere AC "Hospital Grade" grounded (protectively earthed) outlet for the MCH.**
-  **CAUTION: This equipment is designed to function properly in the presence of radio frequencies typically encountered in a hospital operating room environment. Some RF communications equipment can affect medical electrical equipment.** The operator should assure that this equipment functions properly in the specific environment in which it will be used
-  **CAUTION: When power is not required, disconnect the device from the power source before inspecting, reprocessing, or preparing it for use.**
-   **CAUTION: DRY OPERATION WILL CAUSE EQUIPMENT DAMAGE.** Operate the system with at least 4 inches (10cm) of sterile water or water that has been passed through a filter of less than or equal to 0.22-microns. Do not completely drain the system while in an operating mode.
-  **CAUTION: The water tank should remain covered to prevent debris from entering the system or water vapor from escaping, and to minimize the loss of ice temperature.**
-  **CAUTION: Do not use acetone-based cleaning solutions to clean the unit.** Acetone-based cleaning solutions will cause equipment damage.
-  **CAUTION: Use only CardioQuip approved cleaners and disinfectants.** Operation with unapproved agents may cause equipment damage.



















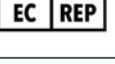

 **CAUTION: Do not use sharp objects to adjust or select switches on the control panel.**

 **CAUTION: Do not lift the MCH by the drain or water/hose connections.** Lifting by these connectors will cause equipment damage.

 **CAUTION: Ensure device and module lids remain closed during use.** If sterile ice/water or ice/water that has been passed through a filter of less than or equal to 0.22-microns must be added during use, ensure the lid is immediately replaced afterwards.

 **WARNING: The MCH-1000 is not a sterile device.** Touching a patient immediately after touching the MCH could lead to patient infection. Follow CDC guidance for hand sanitization before touching a patient or their immediate environment.

Device Labeling

	Device is Type BF medical equipment per IEC 60601-1
	Conductors carrying high voltage are nearby
	Consultation of documentation is critical to safe operation
	AC Power Input
	Chassis grounding locations for protective earth ground
	Manufacturer information
	Date of manufacture
	Operation of the tank and system drains
	Mains power switch for the refrigeration system
	Consult instructions for use
	EC Authorized Representative
	Empty device weight
	Relative Humidity Limitation
	Temperature Limit
	NRTL Certification
	Serial Number
	DC Power Input
	Connection point for the Control Unit
	Indicates the item is a medical device.
	Country of manufacture
	Model Number

Specifications: MCH-1000

Dimensions (LxWxH)	MCH-1000(i): 26x16x35 in (66x42x89 cm) MCH-1000(m): 19x9x16 in (48x23x42 cm)
Weight (empty/full/max)	MCH-1000(i): 85 lbs (39 kg) / 165 lbs (75 kg) / 258 lbs (117 kg) MCH-1000(m): 45 lbs (21 kg) / 65 lbs (30 kg) / 76 lbs (34 kg)
Water capacity	MCH-1000(i): Min 3 gal. (12 L), Max 9 gal. (36 L) MCH-1000(m): Min 1 gal. (3.8 L), Max 2.5 gal. (9.5 L)
Water Connections	Quick-connect, no-spill two-way shutoff fittings. Tank drain accepts standard garden hose (GHT) fitting.
Maximum pressure	83 kPa / 12 psi (closed loop, blocked flow)
Electrical	115VAC / 60Hz, 16A (Class 1 equipment per UL 544) 230VAC / 50Hz, 10.4 A (Class 1, Type BF equipment per UL 2601-1)
Temperature control	Range 0.0 - 42.0°C, Accuracy $\pm 0.5^\circ\text{C}$, Setting 0.1°C
Alarm sound pressure range	41 - 58 dB
Induced airflow	<50 ft ³ /min
Operating environment	5 - 40°C, 0 - 90% humidity
Power consumption	Max Peak 1900 W, Typ < 1740 W
Ground resistance	Max 0.2 Ω
Leakage current	< 100 μA
EMC compliance	CISPR 11:2009+A1:2010, IEC 61000-3-2:2005/A1:2008/A2:2009, IEC 61000-3-3:2013, IEC 60601-1-2:2014

Specifications: Optional MCH-10RMS Refrigeration Module

Dimensions (LxWxH)	Installed in MCH-1000(i): 26x16x45 in (66x42x114cm) Standalone: 20.5x10.5x26.5 in (52x27x68 cm)
Weight	72 lbs (33 kg)
Induced Airflow	<300 ft ³ /min
Power Consumption	Max Peak 690 W, Typ <600 W
Electrical	115VAC/ 60Hz, 6A 230VAC/ 50Hz, 3A (Class 1, BF equipment per UL 2601-1)
Leakage current	<100μA
Ground Resistance	Max 0.2Ω
Operating Environment	5-40°C, 0-90% humidity

Specifications: Optional MCH-11TEC Thermoelectric Cooling Lid Module

Dimensions (LxWxH)	Installed in MCH-1000(m): 19x9x17.25 in (48x23x42 cm) Standalone: 14.5x9x8.5 in (36.8x22.9x21.6 cm)
Weight	8.65 lbs (3.9 kg)
Induced Airflow	<3.5 ft ³ /min
Power Consumption	Max Peak 100 W, Typ < 85 W
Electrical	Input: 100V-240VAC, 50-60 Hz, 1.5-0.6 A
Leakage current	<100μA
Operating Environment	5-40°C, 0-90% humidity

Obtaining Service



Contact CardioQuip with questions on parts, servicing or returning merchandise. Please make sure the unit's model and serial number are available prior to contacting service personnel. If you are experiencing problems with your unit, the service representative will assist you in corrective procedures or in returning the merchandise. Upon request, CardioQuip may make available circuit diagrams, component part lists, descriptions, calibration instructions, or other information which will assist appropriately qualified technical personnel to troubleshoot or repair parts of the equipment that CardioQuip determines to be field repairable. Replacement of internal components may be performed only by CardioQuip service personnel.

Service Contact Information



CardioQuip Service

8422 Calibration Ct.
College Station, TX 77845
USA



US: 888-267-6700
Fax: 979-691-0206
International: +1-979-691-0202



service@cardioquip.com



www.cardioquip.com/service

Limited Warranty

CardioQuip, LLC ("CardioQuip") provides the following limited warranty ("Limited Warranty") to the purchaser ("Customer") of the CardioQuip MCH-1000 Series Cooler-Heater System (the "Equipment").

- A.** This Limited Warranty provides the following assurances to Customer regarding the Equipment:
- (1)** Should the Equipment fail to function within normal tolerances due to a material defect in parts or labor within a period of one (1) year, commencing with the delivery of the Equipment to Customer, CardioQuip will at its sole reasonable discretion:
 - (a)** repair or replace any defective part or parts of the Equipment;
 - (b)** issue a credit to the purchaser equal to the Purchase Price, as defined in Subsection A.(2) below, against the purchase of the replacement Equipment; or
 - (c)** provide a functionally reasonably comparable replacement Equipment at no charge.
 - (2)** As used herein, "Purchase Price" shall mean the lesser of the net invoiced price of the original, or current functionally comparable, or replacement Equipment.
- B.** To qualify for the repair, replacement or credit as set forth in Section A of this Limited Warranty, the following conditions must be met:
- (1)** The Equipment must be returned to CardioQuip within thirty (30) days after Customer's discovery of the material defect. CardioQuip may, at its sole reasonable discretion, elect to repair the Equipment on site.
 - (2)** The Equipment must not have been repaired or altered outside of CardioQuip's factory in any way which, in the sole reasonable judgment of CardioQuip, affects its stability and reliability. The Equipment must not have been subjected to misuse, abuse or accident by Customer.
 - (3)** The Equipment must not have been shipped by commercial carrier beyond the point of CardioQuip's initial shipment.
- C.** This Limited Warranty is limited to its express terms. In particular:
- (1)** Except as expressly provided by this Limited Warranty, CARDIOQUIP IS NOT RESPONSIBLE FOR ANY DIRECT, INCIDENTAL OR CONSEQUENTIAL DAMAGES BASED ON ANY DEFECT, FAILURE OR MALFUNCTION OF THE EQUIPMENT, WHETHER THE CLAIM IS BASED ON WARRANTY, CONTRACT, TORT, OR OTHERWISE.
 - (2)** THIS LIMITED WARRANTY IS MADE ONLY TO THE CUSTOMER. AS TO ALL OTHERS, CARDIOQUIP MAKES NO WARRANTY, EXPRESS OR IMPLIED, INCLUDING, BUT NOT LIMITED TO, ANY IMPLIED WARRANTY OF MERCHANTABILITY, OR FITNESS FOR A PARTICULAR PURPOSE WHETHER ARISING FROM STATUTE, COMMON LAW, CUSTOM OR OTHERWISE. NO EXPRESS OR IMPLIED WARRANTY TO CUSTOMER SHALL EXTEND BEYOND THE PERIOD SPECIFIED IN A.(1) ABOVE. THIS LIMITED WARRANTY SHALL BE THE EXCLUSIVE REMEDY AVAILABLE TO CUSTOMER OR ANY THIRD PARTY.
 - (3)** The exclusions and limitations set out above are not intended to and should not be construed so as to contravene mandatory provisions of applicable law. If any part or term of this Limited Warranty is held to be illegal, unenforceable or in conflict with applicable law by a court of competent jurisdiction, the validity of the remaining portions of the Limited Warranty shall not be affected, and all rights and obligations shall be construed and enforced as if this Limited Warranty did not contain the particular part or term held to be invalid. This Limited Warranty gives Customer specific legal rights. Customer may also have other rights under applicable law which may vary from state to state.
 - (4)** CardioQuip employees have no authority to bind CardioQuip to any representation, condition or warranty except this Limited Warranty.

Storage

If the MCH is to be stored for more than seven (7) days, ensure that the unit is drained and cleaned per the **Quarterly Maintenance Procedure** listed under the **Maintenance** section. The system can be safely stored after performing this procedure. The system and system accessories shall be stored drained and dry (see **System Drain** and **Tank Drain** sections). The MCH shall be stored in an environment where the temperature range is within 0°–43°C (32°–109°F), and the relative humidity is less than 95%.

Transportation

The MCH should be transported in either the original carton, or an equivalent carton, to prevent damage during shipment. If the unit has been in contact with blood, blood components, or body fluids, it must be thoroughly cleaned and disinfected per the **Quarterly Maintenance Procedure** before packing. The MCH should not be exposed to environmental conditions outside of those listed in the **Storage** section.

Lifting

The MCH-1000(i) should be lifted by no fewer than 2 persons and should be drained prior to being lifted. Use proper lifting techniques to avoid injury. The lift points are located at each of the four corners. The lifters' hands should be wrapped tightly around the wheelbase frame projections at each corner (**see Fig. 1**) For short lifts (e.g., assisting the MCH over low obstacles such as cords or thresholds $\geq 10\text{mm}$), the convenience handles may be used with care (**see Fig. 2**). Facing the MCH, with your back to the obstacle, grasp the handle with both hands, with an underhand grasp, and lift upward on the handle while pulling the MCH toward you, over the obstacle.

The Refrigeration Module (MCH-10RMS) should be lifted according to **Refrigeration Module Lifting Instructions**.

The MCH-1000(m) and/or the Thermoelectric Cooling Lid (MCH-11TEC) may be lifted by a single person. The Mch-1000(m) should be drained prior to being lifted. Use proper lifting techniques to avoid injury. The lift points on the MCH-1000(m) are the convenience handles located on the front and back of the device (**see Fig. 3**).



Fig. 1. MCH-1000(i) lift points



Fig. 2. MCH-1000(i) convenience handles

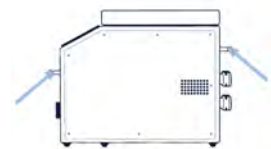

Fig. 3. MCH-1000(m) convenience handles



CAUTION: Do not lift the MCH by the drain or water/hose connections. Lifting by these connectors will cause equipment damage.



CAUTION: Drain the MCH-1000 devices prior to lifting. A full water tank may be difficult to lift and may lead to water spillage.

OVERVIEW

In order to enjoy the greatest reliability from your MCH, please familiarize yourself with the essential parts and basic function of the device.

MCH-1000 Hardware Overview

MCH-1000(i)

Front:

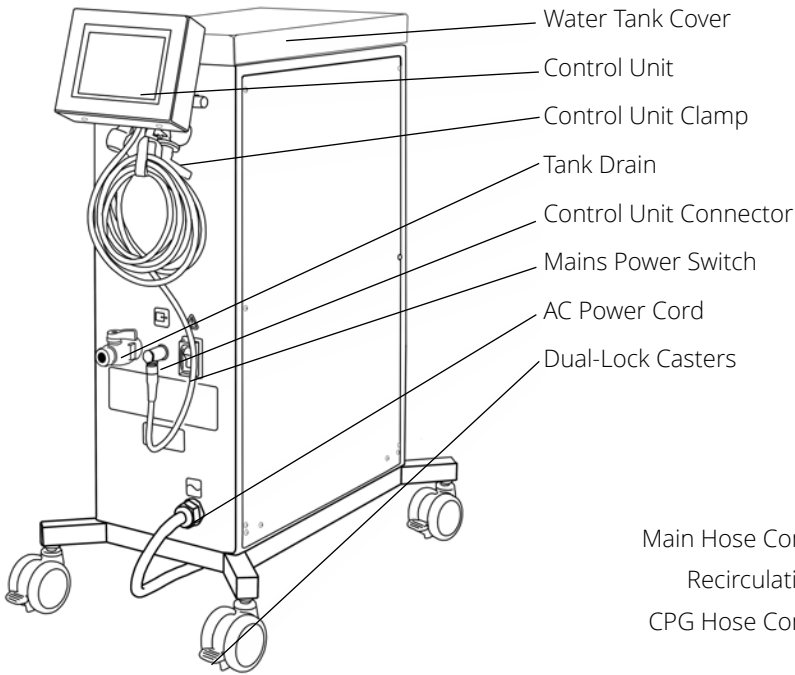

Back:

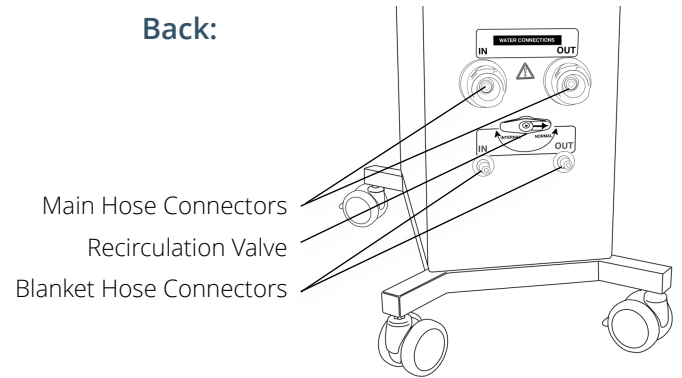

With Cardioplegia Module:

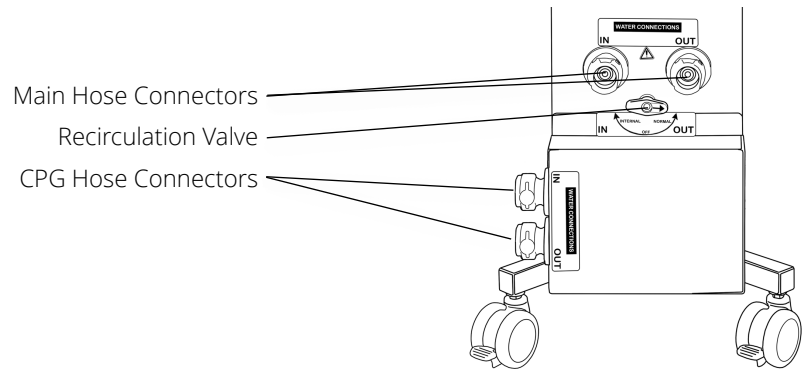

MCH-1000(m)

Front:

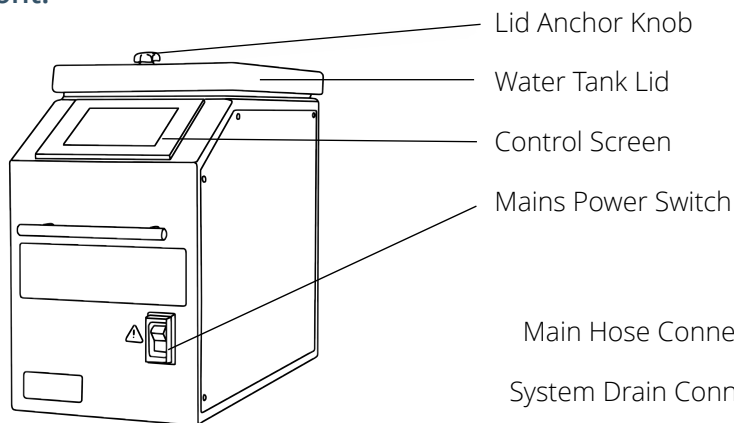

Back:

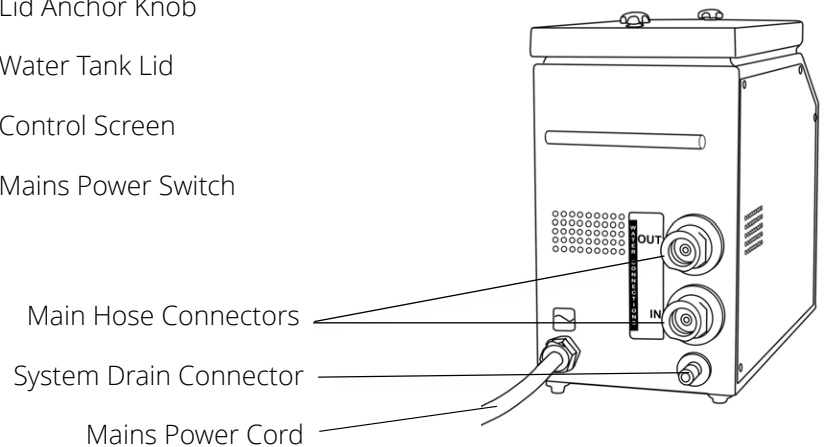

Optional Module Hardware Overview

MCH-10RMS Refrigeration Module

Front:

Back:

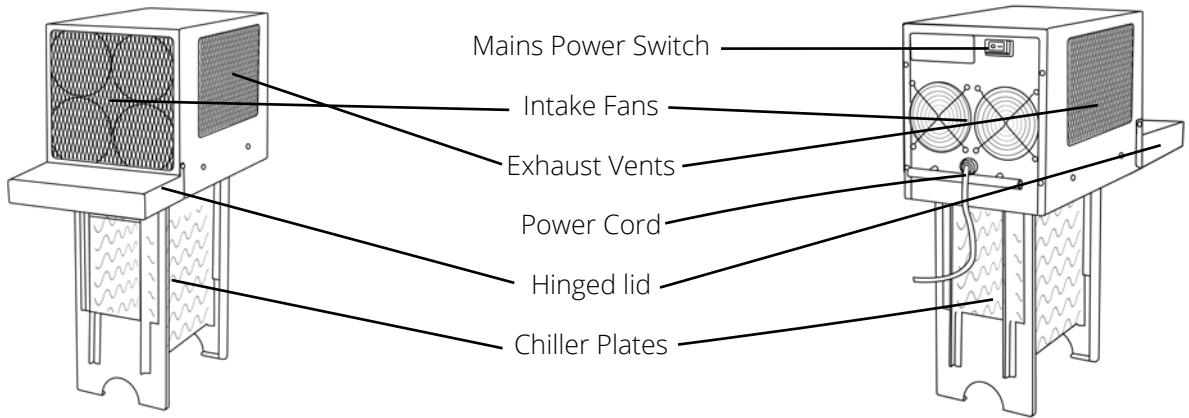

MCH-11TEC Thermoelectric Cooling Lid Module

Front:

Back:

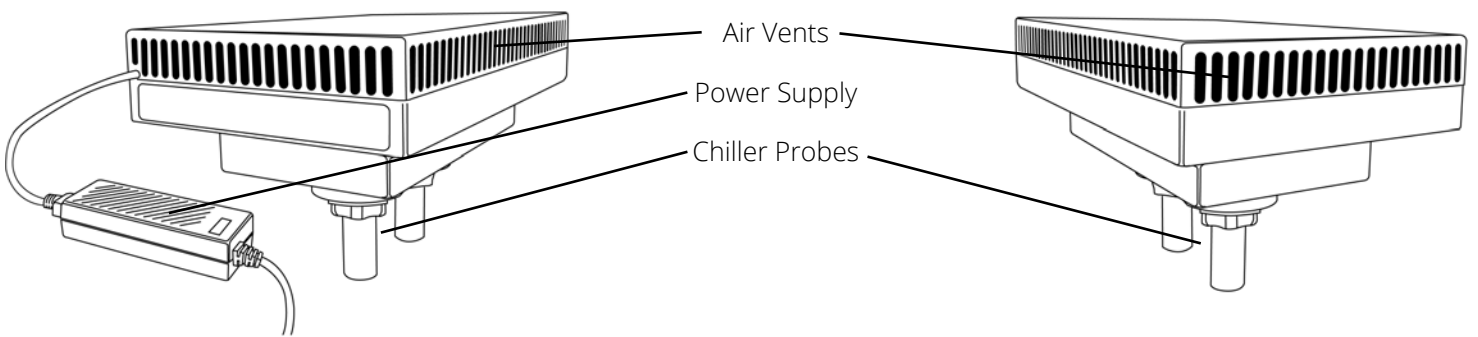

Operation Overview

The MCH operating software serves two basic functions. First, it provides an intuitive, feature-rich touchscreen control interface, giving the operator quick access to temperature settings, pump speed control, system test and status information, and customization features. Second, it constantly monitors the MCH's internal systems to ensure that the hardware is functioning properly. An alarm will sound within seconds of any operational problem, alerting the operator to the issue.

The operator controls the MCH using an LCD touchscreen display, using four basic modes. In **TESTING** mode (which is run automatically when the system is powered on), the MCH tests all internal relays and displays the results to the operator in a simple pass/fail format. In **STANDBY** mode, the system is idle, awaiting operator input. In **PRIMING** mode, the MCH operates the pump and valve to remove air from the tubing lines. In **RUN** mode, the device circulates the water through the water tank and the heater chamber as necessary to maintain the circulating water at the operator-selected temperature.

The MCH is designed with EMI protection to operate effectively with minimal interference from other nearby equipment. It is shielded so that electronic noise generated within its enclosure will not affect operation of other equipment in use in the same area as the MCH.

Unpacking

Carefully inspect the shipping carton or box for damage. If damage has occurred, contact the carrier and request a damage report prior to opening the carton or box. Notation of damages with the delivery person will speed the filing of damage claims.



CAUTION: Do not lift the MCH by the drain or water/hose connections. Lifting by these connectors will cause equipment damage.

To open the MCH-1000(i) or Refrigeration Module (MCH-10RMS) carton, carefully cut the strapping material at the bottom of the carton. Lift and remove the upper portion of the carton. Lift the unit (per the **Lifting instructions**) from the base of the carton and place directly on the floor. Check the carton to be sure that no loose parts or documents are inside. Store the carton for later shipment of the MCH.

To open the MCH-1000(m) or Thermoelectric Cooling Lid (MCH-11TEC) box, remove the tape seal on the box. Remove any packaging inserts, and carefully lift the unit (per the **Lifting instructions**) out from the top of the box and place it onto a flat surface. Check the box to be sure that no loose parts or documents are inside. Store the box for later shipment of the MCH.



Add Ice!

The MCH uses sterile ice or ice made from water that has been passed through a filter of less than or equal to 0.22 microns. It has a valved, insulated water tank that is able to retain ice for a considerable length of time. For procedures that do not require extensive cooling, the MCH will operate safely and effectively with room-temperature sterile water or water that has been passed through a filter of less than or equal to 0.22-microns in the tank. However, the temperature control algorithms are optimized for the use of sterile ice water or ice water that has been passed through a filter of less than or equal to 0.22-microns. The MCH will operate more efficiently with water (0-10°C) in the tank.

CONTROL SCREENS

Power-on

When the Mains Power Switch is first turned on, the CardioQuip logo will appear on the Control Unit screen along with the text, "Initializing..." to indicate that the MCH is booting. After approximately five seconds, the MCH will enter operational mode. If this screen remains active for more than a few seconds, check the connection between the Control Unit and the Main Unit.



Water Level

The water tank must contain at least four inches (10 cm) of sterile water or water that has been passed through a filter of less than or equal to 0.22-microns for basic operation. If at any time the tank water level drops below safe operating level, the Control Unit screen will display the Low Water warning screen shown at right. An audible alarm will sound a two-beep pattern at 20 second intervals. The alarm may be silenced for 60 seconds by touching the Alarm Silence icon at the bottom left corner of the screen.

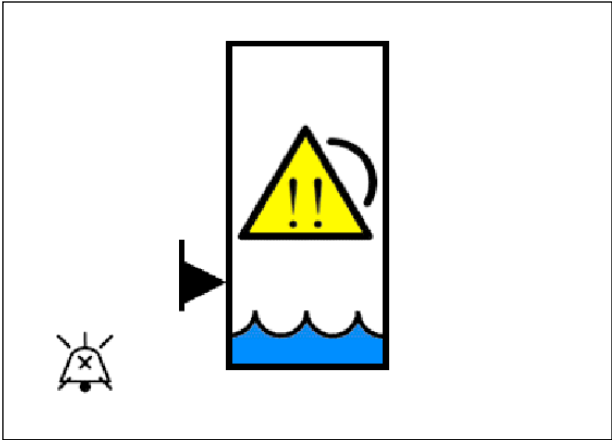

CAUTION: Operating the MCH without water will cause equipment damage.



Note: When the Refrigeration Module is installed, the tank should be filled to the top edges of the chiller plates with sterile water or water that has been passed through a filter of less than or equal to 0.22-microns.

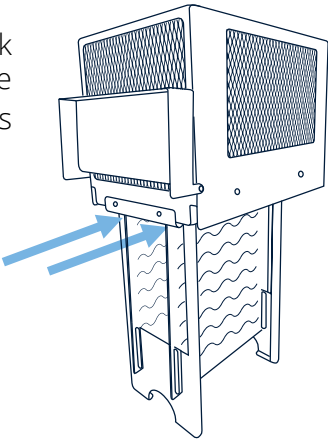

System Test

On startup, the MCH enters **TESTING** mode and runs a system test to verify proper operation of all internal components. Onscreen indicator lamps display the status of control and feedback signals for the various internal systems, and the “Test Status” column (far right) displays the test results. If any test fails, its “Test Status” will display a red **X** symbol and the **FAILURE** screen will appear. Touching the **Retry** button will retry the system test. The MCH will not enter operational mode if any internal system test fails.

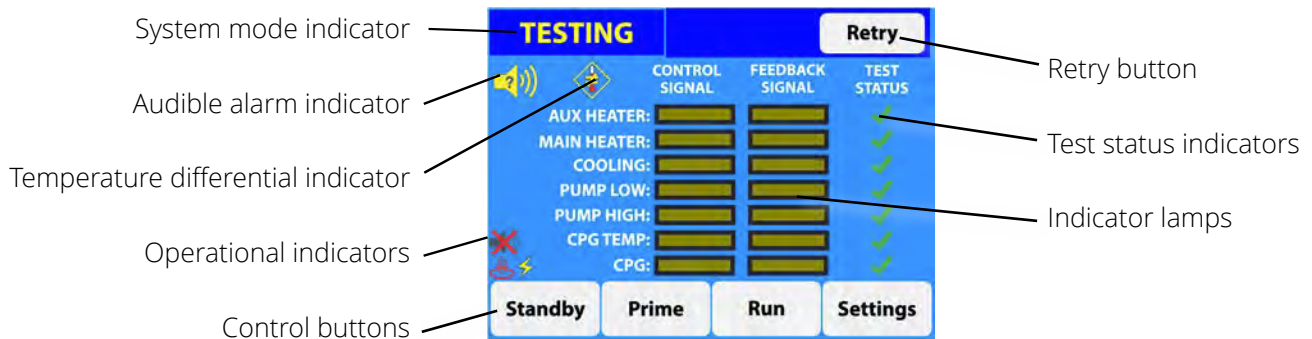

Once the system test has successfully completed, the operator must press the **Standby** button to enter Standby mode.

CAUTION: At the end of a system test, the audible alarm will sound once. The operator must verify that the alarm is audible within the operating environment.



Temperature Differential Indicator Symbol

This symbol is the **Temperature Differential indicator**. When displayed onscreen, it indicates that the measured temperature differential between the MCH’s two internal temperature controllers is greater than 2.5°C. This is usually caused by blocked or impeded water flow. Check the water path to be sure connectors are fully seated, hoses are not kinked, valves are fully open, and the **internal recirculation valve** (if so equipped) is fully in either the **NORMAL** or **INTERNAL** position. If the MCH runs in this condition for more than ten seconds, it will automatically cease operation and display a **FAILURE** screen.

Standby

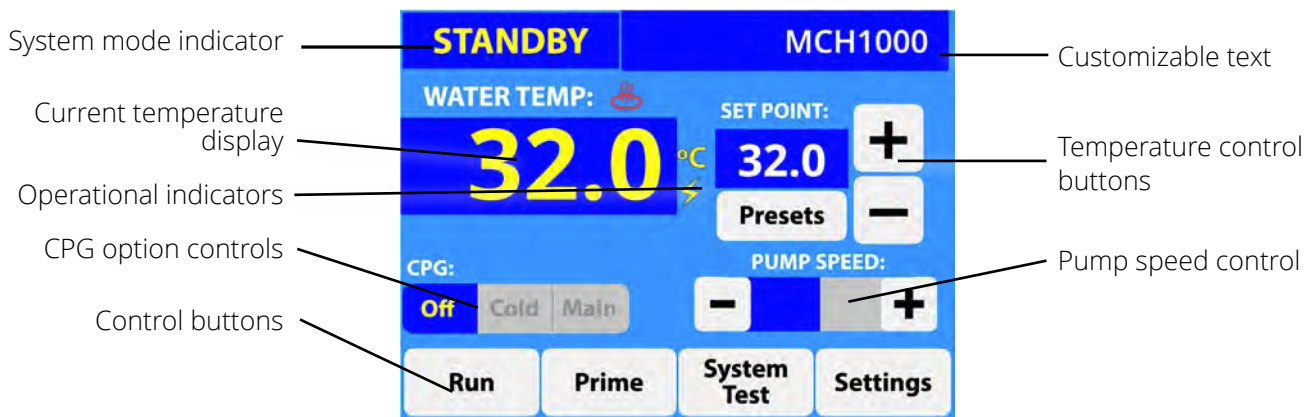

In **STANDBY** mode, the pump and heaters are off, and the operator is able to preset the desired temperature and other settings in preparation for entering **RUN** mode.

To set the desired temperature in tenth-degree increments, touch the **+** or **-** temperature control button. Holding the button for more than one second will cause the temperature setting to change more rapidly. Alternatively, touching the "SET POINT" temperature field will cause a numeric keypad to appear onscreen, allowing direct input of the desired temperature. After entering the desired temperature, touch the **ENT** button to confirm, or touch **ESC** to cancel.

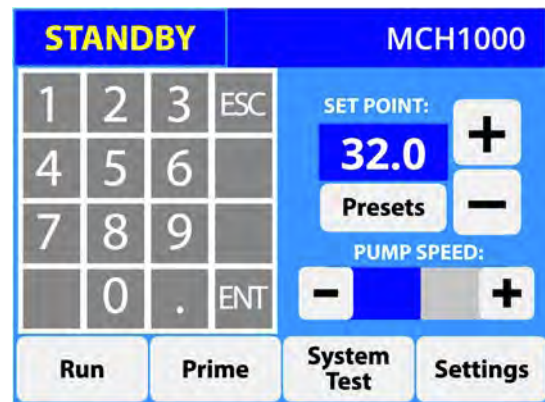

To modify the **customizable message** at the top right of the screen, touch the message field to bring up an alphanumeric keypad onscreen.

After entering the desired customized message (up to 12 characters; e.g., "CARDIOPLEGIA"), touch the **ENT** button to confirm, or touch **ESC** to cancel.

The temperature setting, temperature presets, and customized message are stored in non-volatile memory, and will be retained until changed.

Priming

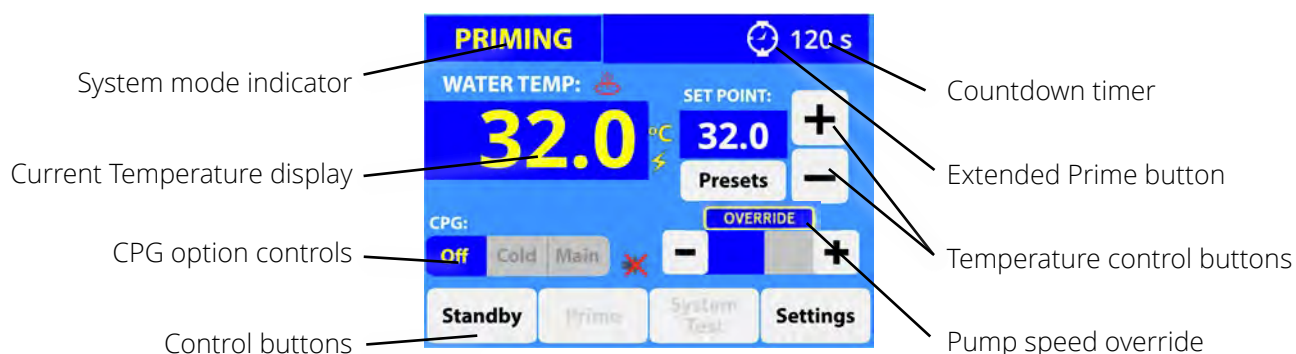

From the **STANDBY** screen, touch the **Prime** button to enter **PRIMING** mode. While the MCH is designed to be largely self-priming, running a priming cycle will remove all air bubbles from the lines, offering quieter operation and better heat transfer. During the priming cycle, the pump runs at high speed, and the cooling control valve automatically alternates the water flow between cooling mode and recirculating mode every ten seconds. No operator intervention is required. The MCH may be returned to **STANDBY** mode at any time by pressing the **Standby** button.

The standard priming cycle length is 2 minutes, but touching the **Extended Prime button** —the stopwatch icon to the left of the countdown timer—will increase the priming cycle length to 10 minutes. This feature is most useful when performing the **Quarterly Maintenance** procedure.



During priming, if the pump speed setting is below maximum, the MCH will automatically override the setting for the duration of the priming cycle. When this occurs, the **PUMP SPEED** label will change to an **OVERRIDE** label. Once priming is complete, the pump speed will return to the preset.

Settings

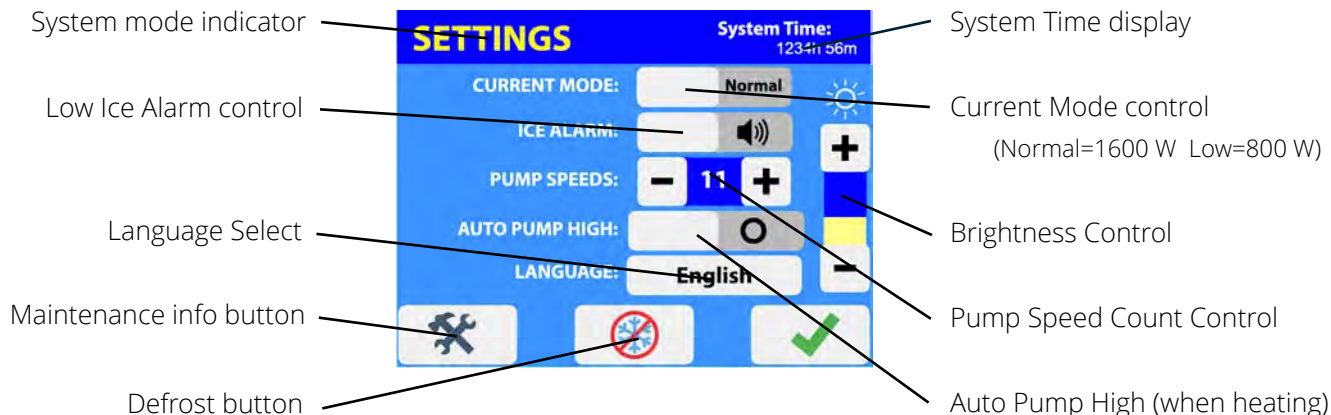

The **SETTINGS** screen may be accessed from any operational screen by touching the  button. This screen allows the operator to put the MCH into low-current mode, enable/disable the Low Ice alarm, set the number of available pump speeds, enable/disable the Auto Pump High feature, change the display language, and initiate the **DEFROST** cycle.

System Time: Displays the number of hours and minutes the MCH-1000 has been in operation.

Current Mode: Allows the operator to reduce the electrical current draw (e.g., when running on battery or generator power). In “Normal” mode, the full 1600W of heat is enabled. In “Low” mode, the heater wattage is halved to approximately 800W.



Low Current mode is indicated onscreen by an operational indicator that looks like a yellow lightning bolt.

Low Ice Alarm: Sounds a short alarm at 20-second intervals if the MCH is in cooling mode and is unable to reach the desired temperature due to insufficient ice.



Pump Speed Count: Controls the number of available pump speeds, up to 11. The pump speeds are calibrated to provide approximately equal flow rate increments. For single-speed operation, set this parameter to one (1). In this mode, the pump speed control buttons will not appear on any screens, and the pump will run at full speed.

Auto Pump High: Automatically sets the pump at full speed when the MCH is heating at full power. This ensures maximum heat delivery to the heat exchanger, and also helps prolong the life of the heaters.

Defrost

The MCH incorporates a built-in defrost cycle, which utilizes the heaters in a special recirculating mode to melt the ice in the water tank. Once the water in the tank reaches room temperature, the MCH automatically returns to **STANDBY** mode. The **DEFROST** function is accessed from the **SETTINGS** screen. To defrost properly, the MCH must either have a hose loop connected, or have its **recirculation valve** (if so equipped) set to **INTERNAL** mode.



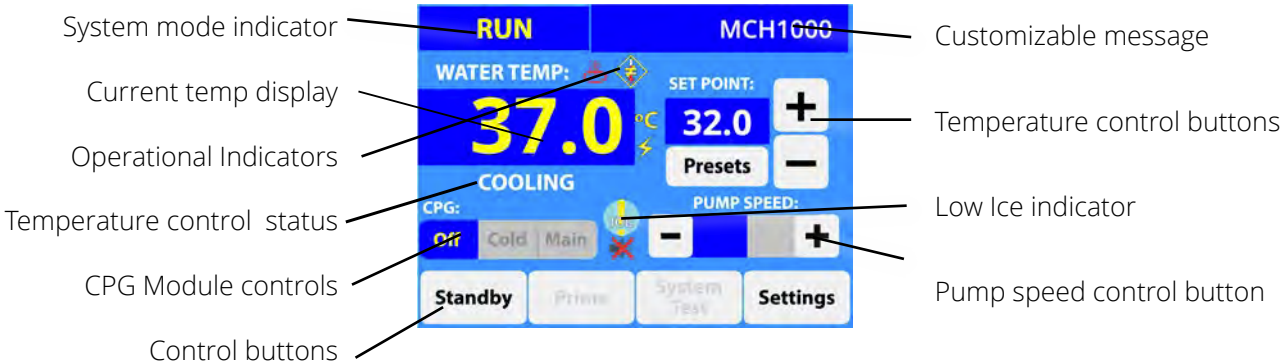

-   **CAUTION: DRY OPERATION WILL CAUSE EQUIPMENT DAMAGE.** Operate the system with at least 4 inches (10cm) of sterile water or water that has been passed through a filter of less than or equal to 0.22-microns.
-  **CAUTION: The Refrigeration Module must be powered off while the DEFROST function is activated.**

Run



The **RUN** screen may be accessed from the **TESTING** or **STANDBY** screens by touching the **Run** button at the bottom of the screen. In this mode, the pump is running, water is circulating, and temperature control is active.

-   **CAUTION: DRY OPERATION WILL CAUSE EQUIPMENT DAMAGE.** Operate the system with at least 4 inches (10cm) of sterile water or water that has been passed through a filter of less than or equal to 0.22-microns.

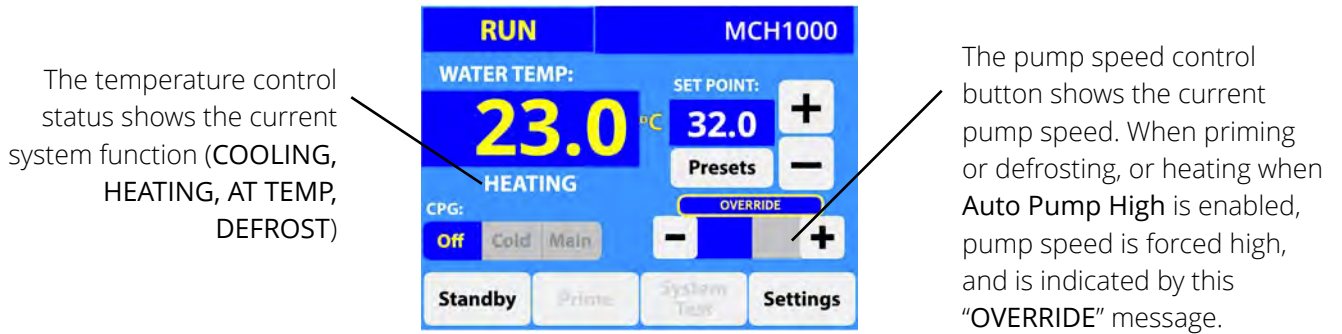

Run Lock

For MCH-1000 units running software version 02.02.14 (released August 2022) or later, RUN LOCK allows users to lock the MCH touch screen to prevent unauthorized or unintentional changes to the RUN parameters.

To activate **RUN lock** screen, press and hold the RUN label at the top left of the RUN screen for >5 seconds. A light blue status bar will appear above the RUN label while the RUN label is pressed (see Fig. 1). Once locked, a pad lock icon bar will appear at the bottom of the screen.

To Deactivate the **RUN lock** screen, press and hold the padlock icon bar at the bottom of the screen for >5 seconds (see Fig. 2). While pressed, a light blue status bar will appear above the pad lock icon bar.

Fig. 1: Activating Run Lock

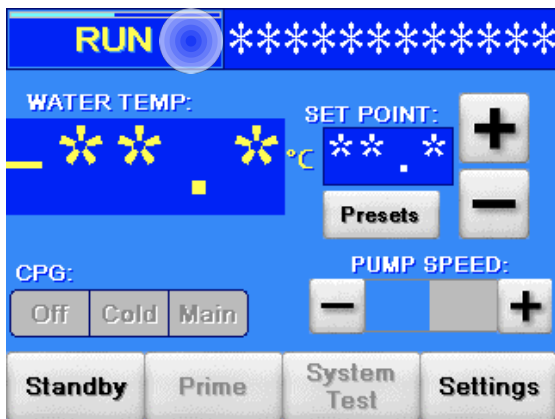
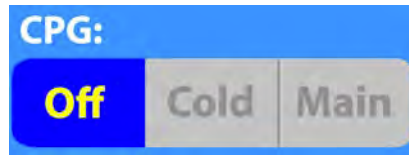

Fig. 2: Deactivating Run Lock



Cardioplegia Shared Channel

The **CPG Module controls** are only visible if the **Cardioplegia Shared Channel Module (MCH-10CSC)** is installed, and offer the following operational modes:



Off Water does not flow through the CPG circuit.

Cold Water is circulated directly from the MCH water tank through the CPG circuit by a secondary water pump. The temperature of the water in the CPG circuit is determined by the temperature of the water in the water tank. This mode is designed to deliver cold cardioplegia, and may be used as a water source for the Quest MPS™. **If the MCH is delivering water in STANDBY mode (so the primary water pump is not running), this button will blink.**

Main The CPG circuit is connected to the Main circuit, and the secondary water pump is off. Water is circulated through the CPG circuit at the same temperature as the Main circuit. This mode is useful for delivering a “warm shot” at the end of a procedure, or for connecting a patient blanket. With software version 02.02.14 (released August 2022) or later, the MCH better maintains the main channel temperature when in CPG “Main” mode, opening the CPG channel valves only when the main channel temperature rises above its initial temperature. This results in a more gradual warm shot, but keeps the main channel temperature more stable. The overall patient rewarm time is not significantly affected.

During the equalization period, the “Main” button on the MCH screen will flash when flow is paused on the CPG water channel in order to allow the main circuit to rewarm to its initial temperature.

Note: In previous versions of software (02.02.13 or earlier) switching from “Cold” to “Main” may cause a short term temperature fluctuation in the Main circuit due to the introduction of water from the CPG circuit. To reduce this fluctuation, the MCH will automatically pre-heat the internal heaters for approximately ten seconds before making the switch.

ALARMS

The MCH incorporates various alarms, enabling auditory monitoring of the system and alerting the operator to any conditions that require the operator's attention. A low priority alarm alerts the operator to a condition that requires attention but poses minimal risk to the patient. A medium priority alarm requires prompt operator attention to avoid potential reversible injury to the patient. A high priority alarm indicates an immediate patient safety issue.

Low Water Level (medium priority)



If the water level in the MCH water tank falls below a safe operating level, the MCH halts its operation, the Low Water Level screen appears, and the alarm sounds a three-beep sequence every 8 seconds. To resolve the Low Water Level alarm, add sterile water or water that has been passed through a filter of less than or equal to 0.22-microns to the tank to a depth of at least 4 in (10 cm) or turn off the mains power switch on the front of the MCH. The audible alarm may be silenced for 60 seconds by touching the Audio Silence button at the bottom left corner of the screen.

Low Ice (low priority)



If the MCH is unable to cool to the set temperature within 40 seconds due to insufficient cold water in the tank, the **Low Ice alarm** sounds a short double-beep alarm every 20 seconds. This alarm is accompanied on the **RUN** screen by the indicator icon shown at left. Touching this icon will silence the alarm for 60 seconds. The Low Ice audible alarm may be disabled on the **SETTINGS** screen or resolved by adding ice made with sterile water or water that has been passed through a filter of less than or equal to 0.22-microns.





WARNING: Only use ice made with sterile water or water that has been passed through a filter of less than or equal to 0.22-microns.

Overtemp (medium priority)

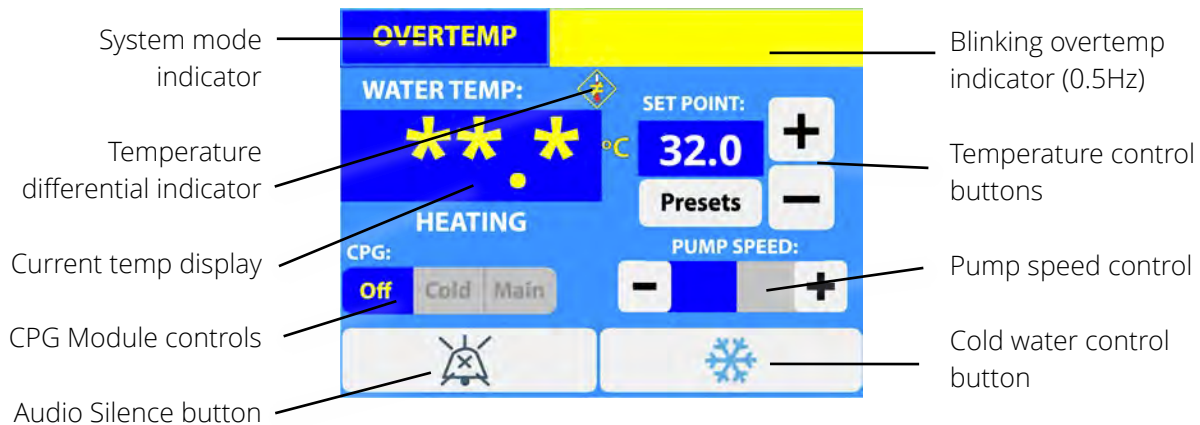
Under normal operation, the MCH software will not allow the water temperature at the outlet to exceed 42.5°C. If the outlet water temperature rises above 42.5°C, the MCH halts its operation, the **OVERTEMP** screen appears, and the alarm sounds a repeating three-beep sequence every 8 seconds.



The audible alarm may be silenced for 60 seconds by touching the **Audio Silence** button  at the bottom left corner of the screen. Touch the cold water control button  (the blue snowflake at the bottom right of the screen) to pump cold water into the lines to reduce the temperature. Once the temperature reaches a safe level, the alarm will clear and the MCH will enter **STANDBY** mode.



WARNING: There must be cold water in the tank to activate Cold Water Control function. If there is warm water in the tank, cold sterile water or cold water that has passed through a filter of equal to or less than 0.22-microns must be added. Two liters (0.5 gal) may be drained from the unit, and an equivalent amount of ice made from sterile water or water that has been passed through a filter of less than or equal to 0.22-microns may be added.



WARNING: If the unit is in an over-temperature condition and the Cold Water Control function is used, it is crucial that the operator monitor the output water temperature.



Temperature Differential (medium priority)





Temperature Differential Indicator Symbol

This symbol is the **Temperature Differential** indicator. When displayed onscreen, it indicates that the measured temperature differential between the MCH's two internal temperature controllers is greater than 2.5°C. This is usually caused by blocked or impeded water flow. Check the water path to be sure connectors are fully seated, hoses are not kinked, valves are fully open, and the **internal recirculation valve** (if so equipped) is fully in either the **NORMAL** or **INTERNAL** position. If the MCH runs in this condition for more than ten seconds, it will automatically cease operation and display a **FAILURE** screen.

System Failure (medium priority)

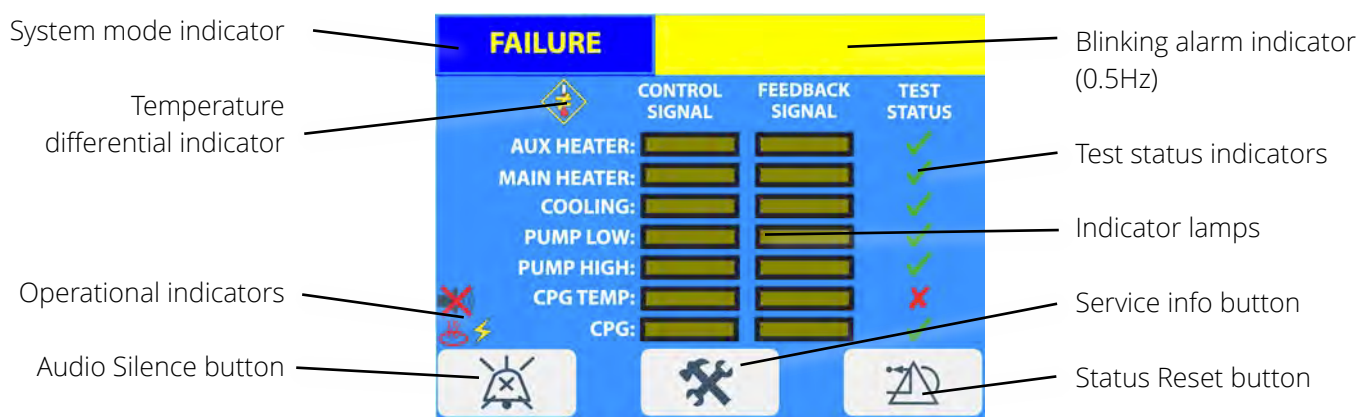
The MCH software constantly monitors the internal systems for problems. If a serious problem is detected, the MCH will halt its operation, the alarm will sound a repeating three-beep sequence every 8 seconds, and the **FAILURE** screen will appear. The MCH subsystem that caused the failure will be marked by a red "X" in the **TEST STATUS** column. Touching the **Status Reset** button  (bottom right) will reset the alarm and cause the MCH to retry the system test sequence. If the system test is successful, the alarm will clear and the **TESTING** screen will appear, with green checkmarks in the **TEST STATUS** column. Otherwise, the **FAILURE** screen will remain, and the alarm will continue to sound. To mute the alarm for 60 seconds, touch the **Audio Silence** button  at the bottom left corner of the screen.



If the **FAILURE** screen is accompanied by this **TEMPERATURE DIFFERENTIAL ERROR** notice, check all hose connections, valves, and connected equipment in the water circuit for blocked flow. Once the water path is confirmed to be clear, touch the **Status Reset** button  to clear the alarm, then return to **RUN** mode.

TEMPERATURE DIFFERENTIAL ERROR
This error can be caused by blocked flow. Please check all connectors, hoses, and valves in the water circuit.

If the FAILURE screen appears repeatedly, this may indicate a serious problem with your MCH unit that could affect patient and operator safety. Even if the system returns to normal operation after a system test or a power cycle, please **contact CardioQuip** for troubleshooting assistance and, if necessary, to schedule a service call.

Audio Silence



When an audible alarm is silenced, the **Audio Silence** indicator is displayed on all operation screens. If the alarm issue remains unattended, the audible alarm will resume after 60 seconds.

SETTING THE TEMPERATURE: 3 WAYS

The set temperature can be adjusted from the **STANDBY**, **RUN**, or **PRIMING** screens. The MCH offers three different methods of adjusting the set temperature:



Tenth-Degree Adjustment

To set the desired temperature, from 0°C to 42°C in tenth-degree increments, touch the **+** or **-** temperature control button. Holding these buttons for more than one second will cause the temperature setting to change more rapidly.



Manual Input

Touching the dark blue **SET POINT** temperature field will cause a numeric keypad to appear onscreen, allowing direct input of the desired temperature. After entering the desired temperature, touch the **ENT** button to confirm, or touch **ESC** to cancel. The MCH will not allow the set temperature to be higher than 42°C or lower to 0°C.



Presets

The set temperature may also be changed using the **Presets** button. This brings up a set of buttons with preset temperatures. Touching one of these buttons changes the temperature Set Point to the preset temperature on the button.

To **edit the preset** temperatures, touch the  button. The temperature buttons will turn yellow. Touch a button to edit the temperature on that button. A numeric keypad will appear onscreen, allowing direct input of the desired temperature preset. After entering the desired temperature preset, touch the **ENT** (Enter) button to confirm, or touch **ESC** (Escape) to cancel.

When you are finished editing the presets, touch the  button to return to the preset selection screen. The temperature setting and temperature presets are stored in non-volatile memory, and will be retained until changed.

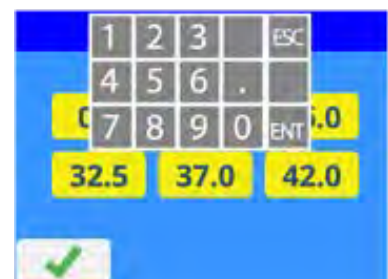
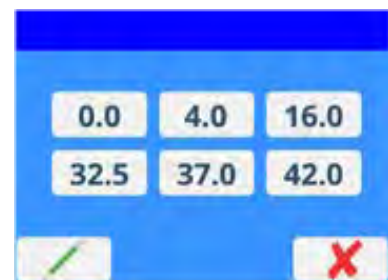

CONNECTORS, VALVES, & HOSES

The MCH series utilizes various non-spill connectors and valves to provide a convenient, drip-free water path. Note that the brass Hansen-style connectors at the remote (oxygenator) end of the standard hose kit are not valved, and will leak when disconnected.



WARNING: This device must not be connected to a heat exchanger or blanket with a manufacturer recommended maximum pressure rating of less than 83 kPa (12 psi). Rupture or leakage may occur in the heat exchanger, resulting in patient injury and/or damage to the system.

Main Hose Connectors

The large dripless connectors on the rear panel of the MCH are for connections to arterial and/or cardioplegia heat exchangers. Maximum water flow at the main connectors is 42 liters/minute (11 gallons/min) with open connectors (unrestricted flow). Actual water flow when connected to a heat exchanger will vary, depending on the flow characteristics of the heat exchanger being used. Water is routed directly from the pump to the OUT connector and recirculated into the system at the IN connector. Water at the OUT connector is under pressure when the system pump is on. These connectors are oriented horizontally on the MCH-1000(i), and vertically on the MCH-1000(m).

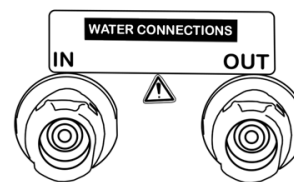

MCH-1000(i) Main Hose Connections



MCH-1000(m) Main Hose Connections

Connecting Hoses

To connect a hose, firmly push the connector straight in until it “clicks,” as shown.



Disconnecting Hoses

To remove a hose, grasp the connector and push the dark grey button on top of the panel connector, as shown below. The connector is spring-loaded and will pop out.

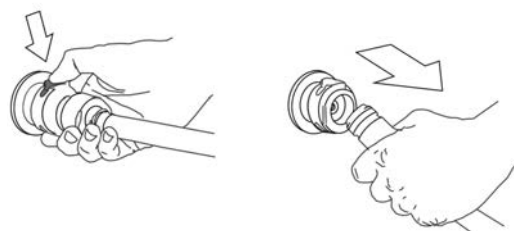

Cardioplegia Hose Connectors

The MCH-1000(i), if equipped with the optional **Cardioplegia Shared Channel (CSC) Module (MCH-10CSC)**, features a second set of hose connectors that are identical to the main hose connectors. Maximum water flow at the cardioplegia connectors is approximately 8 liters/minute (2 gal/min) with open hoses (unrestricted flow). Actual water flow when connected to a heat exchanger will vary, depending on the flow characteristics of the heat exchanger being used. Water is routed directly from the pump to the OUT connector and recirculated into the system at the IN connector. Water flow is controlled by the CPG controls on the touchscreen. These connectors are in a stacked orientation on the side of the MCH-1000(i).

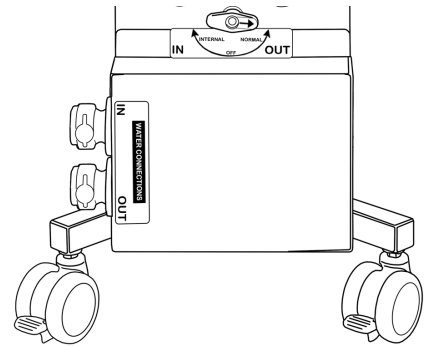

Cardioplegia Shared Channel Module
MCH-10CSC

Internal Recirculation Valve

The internal recirculation valve is located on the rear panel of the MCH-1000(i), and allows the operator to stop water flow through external hoses, recirculating the water internally within the MCH. This may be useful for initial system priming (before hoses are connected), or preheating/precooling water during a procedure. Under normal operation, the valve should remain in the NORMAL position. To disable water flow through the Main & Blanket hoses and enable internal recirculation, turn the valve to the INTERNAL position. To disable water flow completely, turn the valve to the OFF position. This does not affect cold CPG.

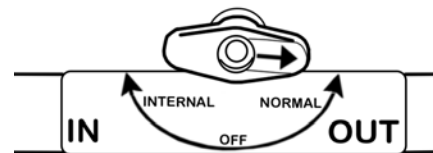

Internal Recirculation Valve set to
"NORMAL"



WARNING: Do not operate the MCH with the valve in the OFF position. Leaving the valve in the OFF position, or in NORMAL without hoses connected, while the MCH is running will cause a temperature-related alarm, and may damage the system.

Blanket Hose Connectors

The smaller connectors on the MCH-1000(i), directly below the “Main” connections on the rear panel of the MCH, are for connections to patient warming blankets. Maximum water flow at the blanket connectors is approximately 4 liters/min (1.0 gal/min). Approximate water flow when connected to a blanket is 1-2 liters/min. The water at the OUT connector is under pressure when the system pump is on.

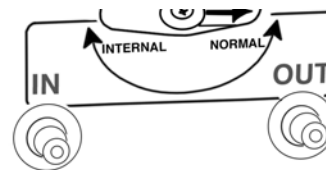

Blanket Hose Connectors

Connecting Blanket Hoses

To connect a hose, firmly push the connector straight in until it “clicks,” as shown.

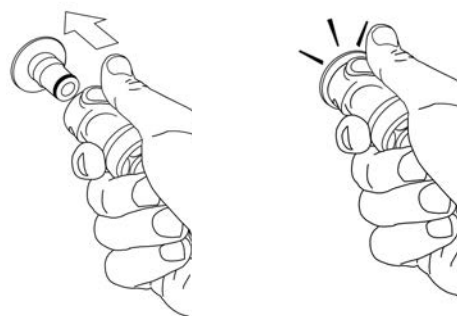

Disconnecting Blanket Hoses

To remove a hose, grasp the connector and push the dark grey button on top of the panel connector, as shown below. The connector is spring-loaded and will pop out.

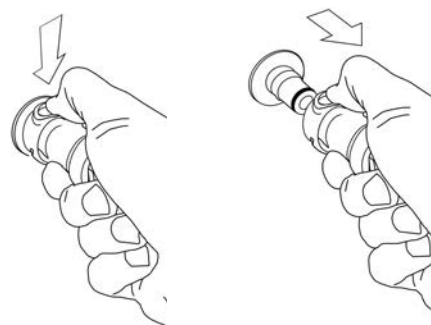

System Drain

The MCH-1000(i) system drain valve is located on the underside of the unit, and allows the operator to drain all or part of the water from the system. To open the valve, move the valve lever down to the vertical position. To close the valve, move the lever to the horizontal position.

System Drain Open

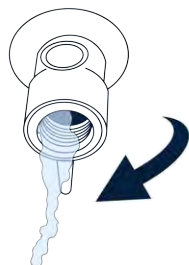

System Drain Closed



The MCH-1000(m) system drain connector is located on the rear of the unit, below the main hose connectors, and operates in the same manner as the blanket hose connectors on the MCH-1000(i).

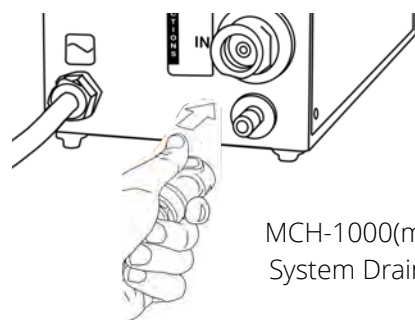

Tank Drain

The tank drain valve is located on the front panel of the MCH-1000(i), and allows the operator to drain water from the water tank without draining the entire system. This may be useful e.g. to make room in the tank for more ice made with sterile water or water that has been passed through a filter of less than or equal to 0.22-microns during a procedure. To open the valve, turn the valve lever so that it is parallel with the valve body. To close the valve, turn the lever to that it is perpendicular to the valve body (see photos below). A hose set equipped with a female GHT fitting may be attached to transfer the water to a remote drain.

Tank Drain Open

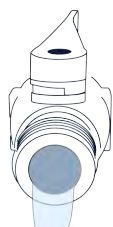

Tank Drain Closed

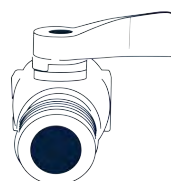

CAUTION: DRY OPERATION WILL CAUSE EQUIPMENT DAMAGE. Operate the system with at least 4 inches (10 cm) of sterile water or water that has been passed through a filter of less than or equal to 0.22-microns.

Hose Kits

The MCH Series supports multiple hose kit configurations to suit the growing array of perfusion applications. The external plastic tubing must be inspected according to the **Weekly Maintenance Procedure**. With any hose kit, quarterly maintenance must include checking the connectors for leaks, and tightening the clamps if needed. To ensure proper function, exterior tubing must be replaced every 2 years regardless of condition. Replacement involves the detachment of the current hoses and attachment of new hoses as outlined in the **Maintenance** section of this manual.

If the external tubing appears cloudy or discolored, immediately remove the device from service and contact CardioQuip Customer Service for details regarding servicing assistance.

Standard Hose Kit

The MCH Series includes a **Standard Hose Kit** (MCH-10SHS and MCH-11SHS), with dripless connectors at one end, nylon-reinforced PVC tubing, ball valves and a short section of flexible clear tubing at the oxygenator end. Standard lengths are 10ft (3m) for the MCH-1000(i) and 6ft (1.8m) for the MCH-1000(m).



Standard Hose Kit
MCH-10SHS / MCH-11SHS

Dripless Hose Kit

The optional **Dripless Hose Kit** (MCH-10DAM and MCH-11DAM) keeps cooler-heater water away from the operating room environment, reducing the risk to the patient of secondary infections from exposure to water-borne pathogens. The kit incorporates PVC tubing with dripless connectors at both ends. The dripless connectors eliminate oxygenator-side water leakage during connection and disconnection. Standard lengths are 10ft (3m) for the MCh-1000(i) and 6ft (1.8m) for the Mch-1000(m).



Dripless Hose Kit
MCH-10DAM / MCH-11DAM

At the end of a procedure, leave the brass Hansen connectors attached to the CPB heat exchanger, and disconnect the dripless connectors. The short sections of hose can be taken out of the room along with the heat exchanger, then disconnected, drained, and returned to the room post-procedure.

Optional Hose Kits with Blanket Adapters

Both the Standard Hose Kit and Dripless Hose Kit for the MCH-1000(i) can be purchased with blanket adapters: **Standard Hose Kit with Blanket Adapter (MCH-10SMB)** and **Dripless Hose Kit with with Blanket Adapter (MCH-10DMB)**.

Note: Blanket adapters are only available for MCH-1000(i) hose sets.

Tank Lid Anchor Knobs

The tank lid of the MCH-1000(m) includes a pair of spring-loaded anchoring knobs, which may be threaded onto posts to secure the lid onto the tank, in order to minimize water spillage while the MCH is being moved. To secure the lid, push down on the knob to engage the post, and turn the knob clockwise. To remove, turn the knob counterclockwise until it disengages from the post. It may be helpful to occasionally lubricate the threads with petroleum jelly or plumber's grease.

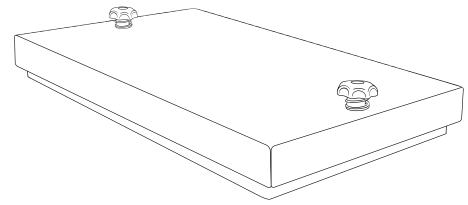

Tank Lid with Anchor Knobs
MCH-11TKL

PATIENT BLANKETS

A **patient blanket** may be used with the MCH to provide external warming or cooling for patients who require it. Common applications include prevention and treatment of hypothermia, fever reduction, and general patient comfort. When a patient blanket is in use, the operator must monitor the temperature of both the patient and the blanket at regular intervals to ensure patient safety.

Any patient blanket used with the MCH must meet IEC 80601-2-35 standards for heating devices. CardioQuip has specifically tested the MCH with the Cincinnati Sub-Zero PlastiPad™ Reusable Plastic Blanket and Maxi-Therm™ Single Patient Use Blanket, and the Adroit Soft-Temp™ WD-060 Single Patient Use Blanket; however, any patient blanket with an operating pressure rating of 12 psi or greater, and an unheated border of less than 30mm, can safely be used with the MCH. When using a patient blanket, it is the operator's responsibility to follow the specific blanket manufacturer's instructions and safety precautions.



WARNING: Follow the instructions for use supplied by the patient blanket manufacturer. Failure to do so may result in a potentially hazardous situation.



WARNING: The blanket surface temperature must remain $\leq 40^{\circ}\text{C}$ to avoid patient injury. The MCH does not monitor the blanket surface temperature, and is capable of outputting water at 42°C .



WARNING: Most patient blankets will be damaged by sharp objects. Puncturing, slicing, or tearing a patient blanket will result in a potentially hazardous situation.



WARNING: Excessive insulation between the patient blanket and the patient will reduce therapeutic effect, and could create a potentially hazardous situation.



WARNING: The use of materials of good thermal conductivity, such as water, gel, and similar substances, when the MCH is not providing temperature control, can decrease the patient's body temperature.



WARNING: The use of patient retention devices may be necessary to keep the patient positioned on a patient blanket. Any such devices must not block the fluid pathways in the patient blanket or the MCH tubing.



WARNING: Warming transdermal medications (patches) can increase drug delivery, which may result in possible harm to the patient.



WARNING: Do not use a patient blanket distal to arterial cross clamping to heat a patient. This can result in burn injuries to the patient.



WARNING: Do not use a patient blanket to heat a patient with an ischemic limb. This can result in burn injuries to the patient.



WARNING: Do NOT move modules or accessories between cooler-heater devices to prevent possible cross-contamination.

Blanket Orientation

For most applications, CardioQuip recommends that the patient blanket be laid flat, without creases or wrinkles, between the bed or table and the patient, according to the diagram below. The blanket should be covered with a thin intermediate layer of insulating material, such as a sheet or thin blanket, to prevent patient discomfort and promote even heat transfer. The MCH should be located below the level of the bed or table, to reduce the potential water volume in contact with the patient and bedding in case of a leak.

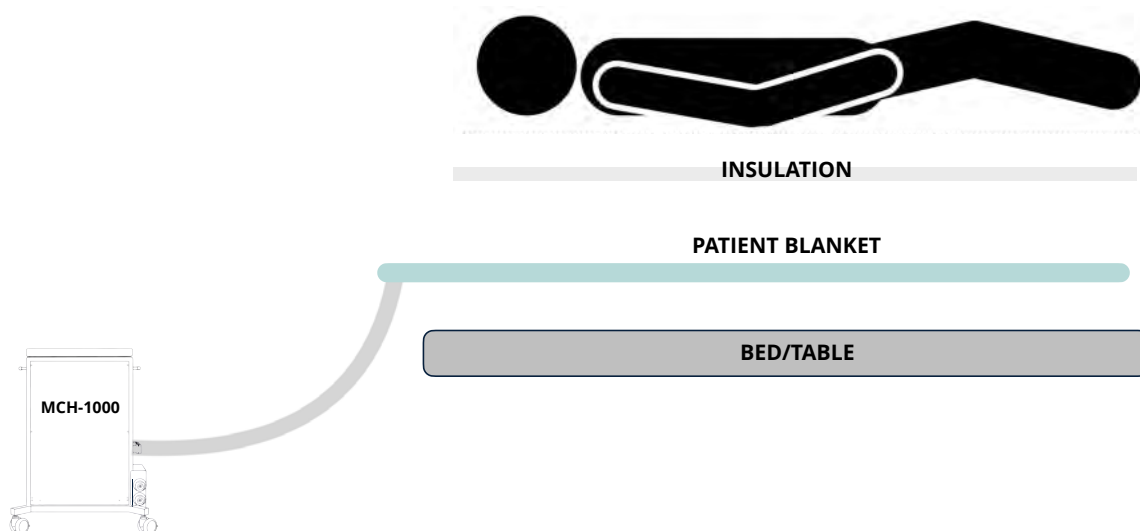

In this configuration, the MCH is capable of heating the contact surface temperature of the patient blanket from $23\pm 2^{\circ}\text{C}$ to 37°C in approximately three minutes. While the MCH is in **RUN** mode and maintaining a stable temperature, the water temperature displayed on the MCH screen is typically within 2°C of the surface temperature of the patient blanket.

While actively heating or cooling, the temperature displayed on the MCH screen will typically “lead” the surface temperature of the patient blanket by $3\text{--}4^{\circ}\text{C}$. In other words, when heating, the displayed temperature will be slightly higher than the blanket surface, and when cooling, the displayed temperature will be slightly lower than the blanket surface. It is the operator’s responsibility to monitor the actual temperature of the blanket and the patient in order to ensure safe operation.

OPTIONAL COOLING MODULES

Thermo-Electric Cooling (TEC) Module

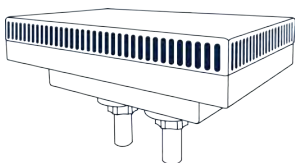

The TEC Module (MCH-11TEC) replaces the lid on the MCH-1000(m) with an enclosed pair of cooling probes that continuously chill the water in the tank, maintaining a water temperature of approximately 5–10°C depending on ambient conditions and load. This provides adequate cooling for most normothermic procedures.



TEC Module Installation

Fill the MCH-1000(m) water tank with sterile water or water that has been passed through a filter of less than or equal to 0.22-microns to approximately $\frac{2}{3}$ full, to a depth of about four inches (10 cm). Store the factory tank lid in a safe place, and carefully fit the TEC Module onto the tank. If water begins to overflow, drain some water from the unit or lift the TEC Module and remove some water from the tank. The TEC Module may be installed with its power cord toward the front or rear of the MCH-1000(m), whichever is more convenient. Connect the TEC Module's power cord to a hospital-grade electrical circuit.

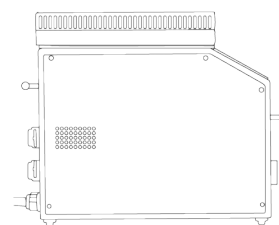

TEC Module Maintenance

During the **Quarterly Maintenance Procedure**, remove the TEC Module from the system and wipe down the chiller probes and underside of the unit with an EPA-registered tuberculocidal disinfectant wipe. Periodically, check the air intake vents on the TEC Module for dust buildup or blockage. Use compressed air as often as needed to clean dust from the air vents and the internal components. Clean outer surfaces with an EPA-registered tuberculocidal disinfectant wipe.

TEC Module Operation

Fill the water tank two-thirds full with sterile water or water that has been passed through a filter of less than or equal to 0.22-microns. Place the TEC Module onto the open tank of the MCH-1000(m). Connect the TEC Module's power cord to a hospital-grade circuit.

TEC Module Storage

The TEC Module can be stored on its own oriented upside down with the chiller probes facing upwards.



CAUTION: Do not plug the TEC Module into the same electrical circuit as the MCH-1000(m). The TEC Module draws approximately 1.5 Amps of power, so it may be able to share a circuit with other equipment. The MCH-1000(m) requires a separate dedicated 20 Amp circuit (see Initial Operation Check).



CAUTION: Do not damage the cooling probes. Damaging the protective coating on the probes may cause corrosion and premature failure of the TEC Module.



CAUTION: The water tank should be no more than $\frac{2}{3}$ full of sterile water or water that has been passed through a filter of less than or equal to 0.22-microns when installing the TEC Module. If the water depth in the tank is more than 4 inches (10 cm), overflow and spillage may occur.



CAUTION: Do not block the air vents around the sides of the TEC Module. Inadequate airflow will cause overheating and premature failure of the TEC Module.



CAUTION: During procedures requiring significant cooling, ice made from sterile water or water that has been passed through a filter of less than or equal to 0.22-microns may be needed. The TEC Module is designed for low-demand normothermic cooling applications.



Refrigeration Module

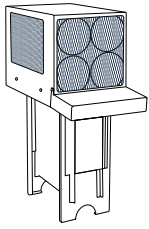

The Refrigeration Module (MCH-10RMS) replaces the lid on the MCH-1000(i) with an enclosed condensing unit that generates a block of ice in the tank. With room-temperature sterile water or water that has been passed through a filter of less than or equal to 0.22-microns, the Refrigeration Module will chill the water to 3°C in about 75 minutes, and begin to make ice in about 1.5 hours.

Refrigeration Module Installation

Remove the factory tank lid from the MCH-1000(i). Team-lift the Refrigeration Module from its shipping crate per the **Lifting instructions**. Always keep the Refrigeration Module upright. When installing the Refrigeration Module, align the rear panel of the unit with the base MCH to ensure that the Refrigeration Module seats properly on the tank lip.

The Refrigeration Module should be installed with its main power cord on the opposite end from the MCH mains power cord, so the hinged lid is toward the front panel of the MCH (**see Fig. 1**). This orientation will give proper clearance for the optional TurboNozzle component which enhances the cooling performance of the MCH-1000.

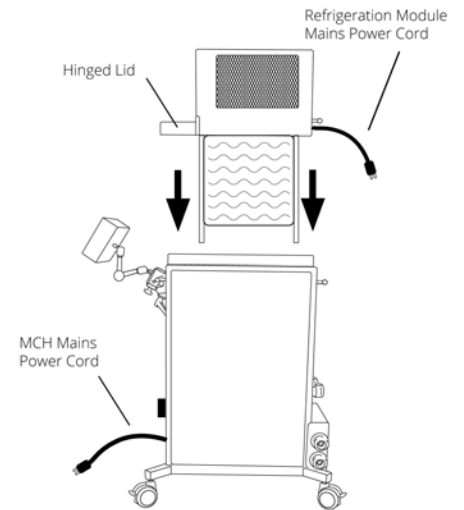
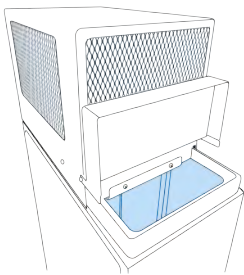

Fig.1 Proper Refrigeration Module Orientation



Refrigeration Module Operation



Fill the water tank with sterile water or water that has been passed through a filter of less than or equal to 0.22-microns until the level reaches the lip of the tank. Maintain this water level while the Refrigeration Module is in use. Connect the Refrigeration Module's power cord to a hospital-grade electrical circuit. Turn on the mains power switch on the rear panel of the Refrigeration Module. **To maintain a proper ice-block, the Refrigeration Module can be left running all the time; doing so will not freeze the entire tank. However, when not in use, the MCH-1000 should be turned off.** Use the hinged lid to inspect the water tank and chiller plates. Keep the hinged lid closed under normal operation.



CAUTION: When not in use or actively circulating water in the cold water tank, the MCH-1000(i) unit should be powered OFF. In certain conditions, keeping both Refrigeration Module and the MCH-1000(i) unit powered on when not in use or actively circulating water may lead to increased ice block size and potentially block flow.

Refrigeration Module Maintenance

Check the air intake & exhaust vents on the Refrigeration Module periodically for dust buildup or blockage. Use a vacuum or compressed air as often as needed to clean dust from the vents and the internal components. Clean outer surfaces with an EPA-registered tuberculocidal disinfectant wipe. During the **Quarterly Maintenance Procedure**, remove the Refrigeration Module from the system according to the Lifting instructions and wipe down the chiller plates and underside of the unit with an EPA-registered tuberculocidal disinfectant wipe.

Refrigeration Module Storage

The Refrigeration Module can be stored on its own, standing upright on its stainless steel stands; however, it is top-heavy and presents a tip hazard when stored in this manner. If possible, it should be stored in place on top of the MCH, with the unit drained and dry.

WARNING: Ensure that airflow from the MCH Refrigeration Module does not violate the sterile field. The Refrigeration Module employs a low-airflow heat exchanger that is designed to function safely and efficiently within the airflow pattern of a standards-compliant Surgical Ventilation System, when positioned as shown in the diagram at right. The MCH should be positioned at least 6ft (2m) from the patient, with the rear-panel water connectors pointing either directly toward, or directly away from, the patient. In this position, the Refrigeration Module exhaust air flows parallel to the operating table. The **Airflow Directional Hood (MCH-10ARH)** may be installed to redirect the exhaust downward. Even with **Airflow Redirection Hood** installation, proper MCH orientation should be followed to ensure exhaust air flows parallel to the operating table. During certain procedures—e.g., with a substandard surgical ventilation system, or with immunocompromised or infectious patients—it may be desirable to power off the Refrigeration Module, to avoid any risk of circulating airborne contaminants that may be present in the room.

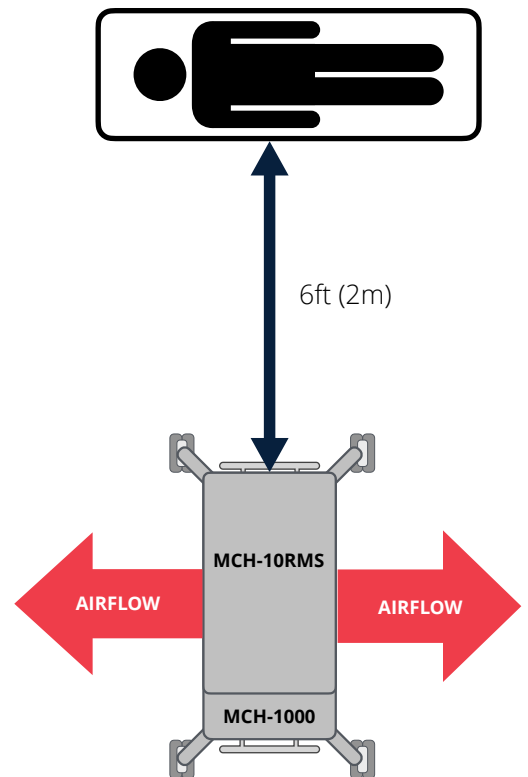

CAUTION: DRY OPERATION WILL CAUSE EQUIPMENT DAMAGE. Operate the system with at least 4 inches (10 cm) of sterile water or water that has been passed through a filter of less than or equal to 0.22-microns.

Refrigeration Module Lifting Instructions

The Refrigeration Module should be lifted by no fewer than two persons. If ice is present on the plates, the unit must be defrosted prior to being lifted. The lift points are at each end of the unit: a handle on the rear, and a handle inside the hinged access lid on the front.

Do not use the hinged lid as a handle.

To remove, lift the Refrigeration Module straight up until the chiller plates clear the top edge of the MCH tank, take a step to one side, and carefully place the unit upright on the floor, using the built-in stands to support the unit. Note that the unit is top-heavy in this position.

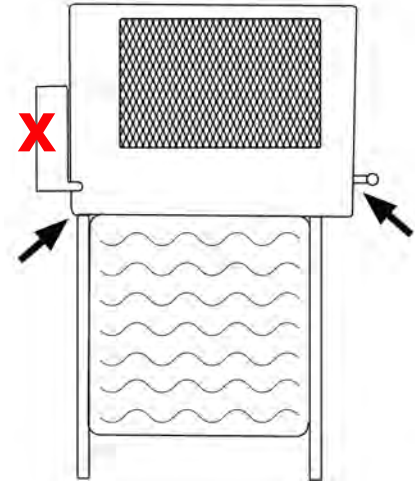

Refrigeration Module MCH-10RMS Lift Points
DO NOT USE HINGED LID AS HANDLE

TurboNozzle for Refrigeration Module MCH-10RMS

The **TurboNozzle** is an optional component that can be used with the Refrigeration Module MCH-10RMS to help lower cold water output temperature by increasing turbulent water flow inside the cold water tank. To obtain a TurboNozzle for your MCH, contact your CardioQuip sales or support representative.

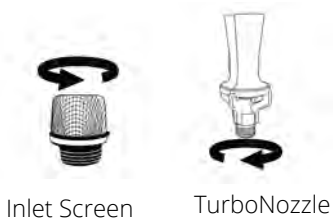

Inlet Screen

TurboNozzle

To install the TurboNozzle, remove the tank inlet screen inside the cold water tank by turning counter-clockwise (the inlet screen is closest to the tank drain and mains power switch side of the MCH). The loose screen can be removed and stored or left inside the tank. Next, install the TurboNozzle by threading it into the tank inlet fitting and turning clockwise (hand tighten only).

Airflow Redirection Hood

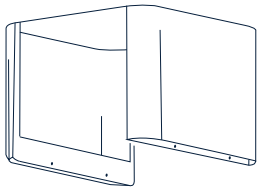

Airflow Redirection Hood
MCH-10ARH

The **Airflow Redirection Hood (MCH-10ARH)** redirects the Refrigeration Module's exhaust downward. This device is a possible risk mitigation component which redirects potential aerosols downwards and away from the surgical field.

Airflow Redirection Hood Installation

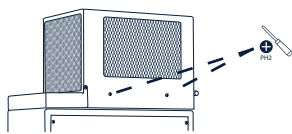

1. With the Refrigeration Module unplugged and powered off, use a #2 Phillips screwdriver to remove the four (4) side panel screws from the Refrigeration Module cover (two per side).

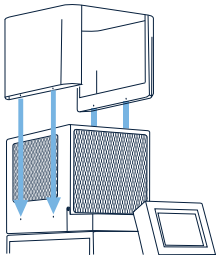

2. Slide the Airflow Redirection Hood down into place on top of the Refrigeration Module. Note the correct orientation of the screw holes in the Airflow Redirection Hood - it only fits properly one way. When the holes are aligned properly, the Airflow Redirection Hood will be centered on the exhaust grille.

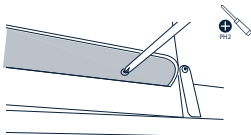

3. Replace the four side panel screws, ensuring that they thread straight in. The screwdriver will be at a slight angle, so care must be taken to ensure that the screws do not cross-thread. Tighten the screws securely.

Airflow Redirection Hood Maintenance

Clean and disinfect the Airflow Redirection Hood concurrently with the **Refrigeration Module Maintenance** as part of the **Quarterly Maintenance Procedure**. Clean outer surfaces with an EPA-registered tuberculocidal disinfectant wipe.

Removal of the Airflow Redirection Hood is required to effectively remove dust or debris from the Refrigeration Module during maintenance.



CAUTION: Do not plug the Refrigeration Module into the same electrical circuit as the MCH-1000(i). The Refrigeration Module draws approximately 6 Amps of power, so it may be able to share a circuit with other equipment. The MCH-1000(i) requires a separate dedicated 20 Amp circuit (see Initial Operation Check).



CAUTION: Do not damage the chiller plates or temperature probe. Bending or twisting the plates or probe can cause premature failure of the Refrigeration Module.



CAUTION: Always keep the Refrigeration Module upright. Setting the module on its top or sides can damage the compressor.



CAUTION: The water tank should be at least 1/2 full of sterile water or water that has been passed through a filter of less than or equal to 0.22-microns when using the Refrigeration Module. If the water depth in the tank is too low, the Refrigeration Module will be unable to produce enough ice for normal device operation, and compressor damage could result. Fill the tank to the top edge of the chiller plates with sterile water or water that has been passed through a filter of less than or equal to 0.22-microns.



CAUTION: Do not block the air vents around the sides of the Refrigeration Module. Inadequate airflow will cause overheating and premature failure of the Refrigeration Module.



CAUTION: Do not operate the Refrigeration Module with the hinged cover open. An open cover inhibits cooling airflow into the unit, and may allow aerosolization of water-borne pathogens that could be present in the water tank.

MCH OPERATION

Physical Inspection

1. Check power cord for cuts, exposed wire, bent or missing pins.
2. Inspect external cabinet and controls for dents or other physical damage.
3. Check that all warning labels are properly affixed.
4. Inspect external water connectors for leaks or physical damage. Look for water accumulation on or under the unit, as this may indicate an internal leak.
5. Clean and inspect the water strainers located in the water tank with a nylon brush.
6. Have qualified service personnel remove side panels and perform steps 7-9.



WARNING: Electric shock hazard. Access panels should be removed only by qualified service personnel.

7. Inspect the inside of the cabinet for water leaks, loose water connections, and visible damage.
8. Inspect the internal wiring for exposed wires, loose connections, and visible damage.
9. Replace the side panels.



CAUTION: DRY OPERATION WILL CAUSE EQUIPMENT DAMAGE. Operate the system with at least 4 inches (10 cm) of sterile water or water that has been passed through a filter of less than or equal to 0.22-microns.

Initial Operation Check

Prior to operation in a clinical setting for the first time, or after extended storage, the following procedures should be performed. Contact CardioQuip if any failures are encountered.



WARNING: It is the operator's responsibility to use, check, and maintain this device according to the labels of the product, accompanying instruction manuals, and any revisions of the labeling or instructions that may be subsequently issued.



WARNING: Proper surgical procedures and techniques are the responsibility of the operator.



WARNING: To avoid the risk of electrical shock, this equipment must only be connected to a supply mains with protective earth.



WARNING: Use a dedicated 20 Ampere AC “hospital grade” grounded outlet.



WARNING: This device must not be connected to a heat exchanger or blanket with a manufacturer recommended max. pressure rating of less than 83 kPa (<12 psi). Rupture or leakage may occur in the heat exchanger resulting in patient injury and/or damage to the system.



WARNING: During clinical operations, do not drain equipment connected to the MCH. Draining attached equipment will drain the entire heat exchanger network.



WARNING: Do not operate the MCH with blocked water flow. Hoses must be attached, and any valves must be open, so that water can flow freely. Operating the MCH without hoses, or with closed valves on the hoses, will damage the pump and void the warranty.



WARNING: If water in the water tank appears discolored, emits a foul smell, or shows visual signs of biofilm, the device must be immediately removed from use. Contact CardioQuip Customer Service for details regarding servicing assistance.



WARNING: If the external tubing appears cloudy or discolored, immediately remove the device from service and contact CardioQuip Customer Service for details regarding servicing assistance.



CAUTION: Position the MCH to allow easy access to the mains power plug. The operator must be able to quickly unplug the device from mains power if necessary.



CAUTION: Do not completely drain the system while in an operating mode. Dry operation will cause equipment damage. Use the tank drain to remove water from the tank for adding additional ice, if necessary.



CAUTION: Do not use sharp objects to adjust or select switches on the control panel.



CAUTION: Do not overtighten the control panel clamp or articulated arm lock. Mechanical damage may result.

MCH-1000(i) Control Module Check

1. Unpack the Control Module and visually inspect for shipping damage (scratched or cracked screen, dents, broken or exposed wires, bent pins, etc.).
2. Using the articulated arm, mount the Control Module on one of the convenience handles on the MCH base unit, or on a suitable pole within reach of the MCH base unit with the Control Module's 15ft (4.5m) cable.
3. Plug the Control Module connector into the front panel of the MCH base unit.

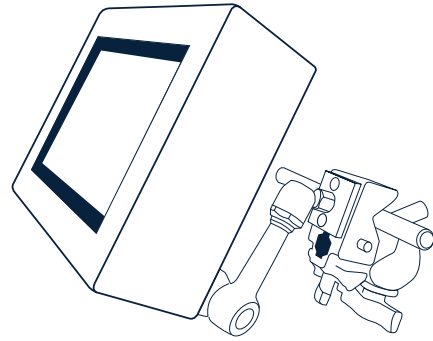

Control Module with articulating mount
MCH-SCRN

MCH-1000 Basic Function Test



1. MCH-1000(i): Attach external hoses with a loopback connector for main circuit and CPG circuit (if so equipped), and add approximately three gallons (12 liters) of sterile water or water that has been passed through a filter of less than or equal to 0.22-microns to the water tank.



MCH-1000(m): Connect a loopback hose to the main hose connectors, and add approximately one gallon (4 liters) of sterile water or water that has been passed through a filter of less than or equal to 0.22-microns to the water tank.

2. With the front panel mains power switch in the OFF position, plug the power connector into a dedicated "hospital grade" power outlet. The outlet should match the voltage, frequency and capacity listed on the MCH nameplate.
3. Turn on the mains power switch. Ensure that the unit runs through a successful system test.
4. Ensure that the cabinet fan located under the system is operational.
5. Inspect the external tubing according to the Weekly Maintenance Procedure to be sure they are clear. Hoses shall be free of kinks, closed valves, etc. that would block water flow through the hose loop.
6. Touch the **Prime** button. The pump should turn on and the valve should switch from cool to recirculation mode approximately every ten seconds (check for ten-second bursts of water flow in the water tank).
7. After priming, ensure the water level in the water tank does not drop below 4 inches by adding sterile water or water that has been passed through a filter of less than or equal to 0.22-microns as necessary.

Refrigeration Module Basic Function Test

1. Install the Refrigeration Module in the tank of the MCH-1000(i). Ensure the power cord on the Refrigeration Module is facing the opposite direction as the power cord on the MCH-1000(i).
2. Connect the Refrigeration Module's power cord to a hospital-grade electrical circuit. Ensure the Refrigeration Module and MCH-1000(i) are connected to different electrical circuits.
3. Turn on the power switch on the Refrigeration Module.
4. Ensure the right rear fan (nearest to the power switch) is operational.
5. After about one minute, ensure the compressor engages and all fans are operational.

TEC Module Basic Function Test

1. Connect the TEC Module's power cord to a hospital-grade electrical circuit.
2. Ensure both fans located inside the top lid of the TEC Module are operational.
3. Ensure the chiller probes become cool to the touch after the TEC Module is powered on.



Temperature Control System Test

1. From the **STANDBY** screen, set the temperature at 0°C, touch the  button, and ensure the system enters cooling mode (water flows into the water tank, temperature control status reads “COOLING”). Note that the output temperature will only decrease to the nominal water temperature in the tank.
2. Set the temp at 42°C and ensure the system enters heating mode (no water flow in water tank, temperature control status reads “HEATING”).
3. Set the system to various temperatures throughout the scale and allow time for stabilization. Check each set point temperature, at the water output, with a reliable temperature standard, to ensure that the temperature displayed is within $\pm 0.5^\circ\text{C}$ of the actual output water temperature. Note that ice made from sterile water or water that has been passed through a filter of less than or equal to 0.22-microns must be added to the water tank in order to achieve set points below nominal water temperature.



WARNING: Only use sterile water or water that has been passed through a filter of less than or equal to 0.22-microns in the MCH. Unfiltered tap water cannot be used with the MCH device for any reason.

Alarm Tests

1. From the **RUN** screen, set the temperature at 42°C. Once the temperature has stabilized at 42°C, check the actual output water temperature with a reliable temperature standard, to ensure that the temperature does not exceed 42°C ($\pm 0.5^\circ\text{C}$). Add hot sterile water or water that has been passed through a filter of less than or equal to 0.22-microns (not more than 60°C) to the water tank. Adjust the temp setting to 30°C to cause the system to pull from the water tank. Carefully monitor the system and ensure that the Overtemp Alarm activates at 42.5°C ($\pm 0.5^\circ\text{C}$). The **OVERTEMP** screen should appear, an audible alarm should sound, and the pump should stop.
2. Touch the **Silence Alarm**  button. The audible alarm should silence for approximately 60 seconds, and the **OVERTEMP** screen should remain.
3. Touch and hold the **Cold Water Control** button . The system should change to Low pump speed and water should flow into the water tank. Add cold sterile water or water that has been passed through a filter of less than or equal to 0.22-microns to the tank, and the alarm should clear. With hot water in the water tank, the alarm will not clear until the water temp in the tank falls below 42°C.



Terminating Operation

The **Standby** button can be used to access the **STANDBY** screen, which stops the pump and halts temperature control operations of the MCH. The mains power switch may be turned off at any time to completely terminate MCH operation. The set temperature and other operator-selectable settings are retained in the device's memory.

Turning off the mains power switch isolates both poles (line and neutral) simultaneously from the supply mains. This may also be accomplished by unplugging the MCH power cord from the wall outlet.

Current Test

Using a calibrated electrical safety analyzer, measure electrical leakage current of the MCH unit under the following conditions: power on and off, polarity normal and reverse, unit grounded and ungrounded. The leakage current should be less than 100 μ A under all conditions. If a unit has leakage current that exceeds 100 μ A or has a significant increase in leakage current, contact CardioQuip Customer Service. Refer to Underwriter's Laboratory or IEC Standards to obtain the current and correct procedures for leakage current measurement.

Initial Cleaning and Disinfection

To prepare the MCH for storage or initial use, perform the Quarterly Maintenance Procedure, which may be found in the **Maintenance** section of this manual.

Normal Operation



WARNING: DO NOT use unfiltered tap water to rinse, fill, refill, or top-off the water tank.



WARNING: If water in the water tank appears discolored, emits a foul smell, or shows visual signs of biofilm, the device must be immediately removed from use. Contact CardioQuip Customer Service for details regarding servicing assistance.



WARNING: If the external tubing appears cloudy or discolored, immediately remove the device from service and contact CardioQuip Customer Service for details regarding servicing assistance.



WARNING: It is the operator's responsibility to use, check, and maintain this device according to the labels of the product, accompanying instruction manuals, and any revisions of the labeling or instructions that may be subsequently issued.



WARNING: Proper surgical procedures and techniques are the responsibility of the operator.



WARNING: The MCH must be properly cleaned and disinfected according to the Quarterly Maintenance Procedure prior to operation or storage to prevent high bacterial count or residual chemicals.



WARNING: Use a dedicated 20 Ampere AC "hospital grade" grounded outlet.



WARNING: This device must not be connected to a heat exchanger or blanket with a manufacturer recommended max. pressure rating of less than 83 kPa (<12 psi). Rupture or leakage may occur in the heat exchanger resulting in patient injury and/or damage to the system.



WARNING: During clinical operations, do not drain equipment connected to the MCH. Draining attached equipment will drain the entire heat exchanger network.



WARNING: Do not operate the MCH with blocked water flow. Hoses must be attached, and any valves must be open, so that water can flow freely. Operating the MCH without hoses, or with closed valves on the hoses, will damage the pump and void the warranty.



WARNING: The use of high frequency (HF) surgical instruments or endocardial catheters with the MCH may increase the risk of electric shock, burns, or electromagnetic interference. Appropriate precautions should be taken to ensure operator and patient safety.



CAUTION: Position the MCH to allow easy access to the mains power plug. The operator must be able to quickly unplug the device from mains power if necessary.



CAUTION: Do not use sharp objects to adjust or select switches on the control panel.



CAUTION: Do not overtighten the control panel clamp or articulated arm lock on the MCH-1000(i). Mechanical damage may result.



CAUTION: Check for mechanical damage to any heat exchanger, blanket, or other applied part, prior to connecting it to the MCH.

1. Attach the desired heat exchanger and/or blanket circuits to the appropriate connectors on the rear panel.
2. MCH-1000(i): Verify that the internal recirculation valve is in the NORMAL position.
3. Check the attached hoses to be sure there are no kinks, closed valves, etc. that would block water flow through the hose loop.
4. Ensure that the water tank contains at least 4 inches of sterile water or water that has been passed through a filter of less than or equal to 0.22-microns, then add ice made from sterile water or water that has been passed through a filter of less than or equal to 0.22-microns, as desired. The amount of ice needed to perform a given procedure is an operator decision; however, it is recommended that each procedure be started with a full supply (approximately 35 lbs. / 16 kg) of ice in the water tank. **Note:** The MCH-1000(m) holds significantly less ice than the MCH-1000(i).



WARNING: DO NOT use unfiltered tap water to rinse, fill, refill, or top-off the water tank.



CAUTION: DRY OPERATION WILL CAUSE EQUIPMENT DAMAGE. Operate the system with at least 4 inches (10 cm) of sterile water or water that has been passed through a filter of less than or equal to 0.22-microns.

5. With the front panel mains power switch in the “off” position, plug the power connector into a dedicated “hospital grade” power outlet. The outlet should match the voltage, frequency and capacity listed on the MCH nameplate.
6. Turn on the mains power switch and ensure that the unit runs through a successful system test.
7. Touch the button to initiate the priming sequence. The pump should turn on and the valve should switch from cooling to recirculation mode approximately every ten seconds (check for ten-second bursts of water flow in the water tank). Allow the system to prime until no air bubbles appear in the external water lines. The priming sequence will automatically run for 120 seconds, which should be sufficient for most applications.
8. Set the desired temperature set point.
9. Touch the button and monitor the water and patient temperature. Adjust the set point as needed to maintain the desired patient temperature.
10. To halt operation, touch the button.



WARNING: The MCH is not fully automatic. Monitoring of patient temperature and rate of temperature change remains the responsibility of the operator.

11. If the water level in the tank is too high to accommodate additional ice, use the tank drain valve or the system drain to drain excess water from the water tank.



Overtemp

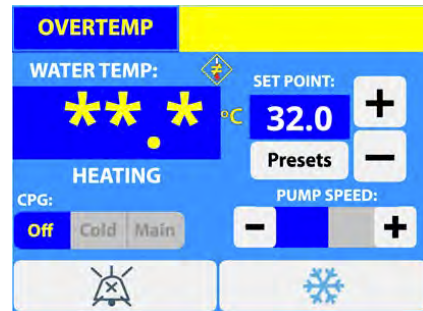

WARNING: If the unit is in an overtemp condition and the emergency cool system is used, it is critical that the operator monitor the output water temperature.

If the output water temperature exceeds 42.5°C, the MCH will enter overtemp mode. The system pump will stop, the **OVERTEMP** screen will appear, and an audible alarm will sound. The operator should perform the following procedure to restore normal operation:



1. Touch the **Silence Alarm button** . The audible alarm will silence for approximately 60 seconds. This allows the operator to clear the overtemp condition without the distraction of an audible signal.
2. Touch and hold the **Cold Water Control button** . The system will change to Low pump speed and into cool mode (water flow into water tank), allowing cool water to flow into the system at a slow rate. The overtemp condition will clear when the water temperature decreases below 42°C.
3. Once the **STANDBY** screen appears, the operator can then check the temperature and pump settings, and touch the  button to return to normal operation.



WARNING: There must be cold water in the tank to activate **Cold Water Control function**. If there is warm water in the tank, cold sterile water or cold water that has passed through a filter of less than or equal to 0.22-microns must be added. Two liters (0.5 gal) may be drained from the unit, and an equivalent amount of ice made from sterile water or water that has been passed through a filter of less than or equal to 0.22 microns may be added.



WARNING: If the unit is in over-temperature condition and the **Cold Water Control function** is used, it is crucial that the operator monitor the output water temperature.

A Note About Flow

The main water pump used in the MCH is capable of delivering up to 60 liters per minute (LPM) of unrestricted flow at a maximum pressure of approximately 12 psi; however, the actual flow rate is ultimately determined by the combined restrictions of internal plumbing and external hoses, heat exchangers, patient blankets, etc. The internal restrictions of the MCH allow a typical maximum flow of approximately 20 LPM. Various configurations of hoses and heat exchangers will exhibit different flow rates. For example, when connected to a Medtronic MYOtherm™ or BIOtherm™ heat exchanger with the standard hose set, the typical range of flow is from 5 LPM at the lowest pump speed to 12 LPM at the highest pump speed.

MAINTENANCE

Deviation from maintenance procedures may result in increased patient risk.



Water Quality

The water in a cooler-heater can harbor various microorganisms commonly found in the hospital environment, some of which can pose health risks for immunocompromised individuals. The only effective way to control these risks is to closely monitor the water quality in the cooler-heater, use only sterile water or water that has been passed through a filter of less than or equal to 0.22-microns, and treat it like any other biohazardous material. For example, gloves used when connecting the water hoses should be discarded before handling other parts of the perfusion circuit, and towels used for absorbing water spills should be treated as contaminated.



Cleaners & Disinfectants

Chemical solvents (MEK, acetone, alcohol, etc.), strong acids or bases, and coarse abrasives should never be used as these may damage polymer face plates, control panels, connectors, etc. Do not allow any anesthetics to spill on any part of the system or spare parts. Chemicals such as Forane (Isoflurane) can be very damaging. When using chemical cleaners or disinfectants, do not mix at stronger concentrations than recommended by the manufacturer, and do not combine chemicals. All chemical mixtures must be diluted with sterile water or water that has been passed through a filter of less than or equal to 0.22-microns to maintain proper water quality. If chlorine bleach is used for disinfection, in order to avoid equipment damage, the diluted concentration must be less than 50 ppm during cleaning and disinfection, and residual chlorine levels must be less than 2 ppm. Suggested chemicals and concentrations for use in cleaning and disinfecting the MCH are listed in the table below:



Disinfectant/Cleaner	Dilution in Sterile Water or Water that has been passed through a filter of less than or equal to 0.22-microns for Disinfection/Cleaning	Acceptable Residual
Pine Sol™ (glycolic acid, ethoxylated alcohols)	0.4 oz/gal (3 mL/L)	0.1 oz/gal (1 mL/L)
Chlorine Bleach (NaClO), 5%	0.13 oz/gal (1 mL/L)	≤ 2 ppm
Hydrogen Peroxide (H ₂ O ₂), 35%	4 oz/gal (30 mL/L)	≤ 2 ppm
Minnicare™ HD Cold Sterilant (peracetic acid, H ₂ O ₂)	1.25 oz/gal (10 mL/L)	≤ 10 ppm
BruTab 6S® Sanitizer Tablets (NaDCC), 3.34 g tablet	2 tablets/gal (4 L)	¼ tablet/gal (4 L)
Liquid Dezcal™ scale remover (sulfamic acid)	13 oz/gal (100 mL/L)	0.1 oz/gal (1 mL/L)



WARNING: When power is not required, disconnect the device from the power source before inspecting, reprocessing, or preparing it for use.



CAUTION: Do not use acetone-based cleaning solutions to clean the MCH. Acetone-based cleaning solutions will cause equipment damage.



CAUTION: Cleaning and disinfection policies and procedures must follow current FDA and CDC guidance.



WARNING: The MCH-1000 is not a sterile device. Touching a patient immediately after touching the MCH could lead to patient infection. Follow CDC guidance for hand sanitization before touching a patient or their immediate environment.

After Every Use

Clean all outer surfaces of the MCH, including modules and accessories, to remove any splattered blood or spilled liquids with EPA-registered tuberculocidal disinfectant wipes. Use only products and processes that are suitable for plastic surfaces. Avoid excess liquid near the control panel.

Weekly Maintenance Procedure

The following weekly inspections shall be used to assess the condition of the tubing and water.

- 1. External Tubing Inspection:** Visually inspect the device's external tubing for cloudiness or discoloration. If the tubing does not appear to be clouded or discolored, return to use.
- 2. Water Quality Inspection:** Lift the lid from the device. Visually inspect the water quality of the tank. If the water is not discolored, does not emit a foul smell, and does not show visual signs of biofilm, close the lid.



WARNING: If the tubing appears cloudy or discolored during the External Tubing Inspection, immediately remove the device from service and contact **CardioQuip Customer Service** for details regarding servicing assistance.



WARNING: If the water appears discolored, emits a foul smell, or shows visual signs of biofilm during the Water Quality Inspection, immediately remove the device from service and contact **CardioQuip Customer Service** for details regarding servicing assistance.

Quarterly Maintenance Procedure

The Quarterly Maintenance procedure is a reprocessing cycle which cleans and disinfects the external surfaces and water path of the unit. To ensure proper operation of the MCH, perform the **Initial Operation Check** at least quarterly. Additionally, ensure all accessories and modules are reprocessed at the same time as the MCH unit. The TEC Module Maintenance and Refrigeration Module Maintenance sections must be referenced for reprocessing their respective modules. Follow the procedure below:



CAUTION: Dry operation will cause equipment damage. Do not operate the MCH with less than 4 inches of sterile water or water that has been passed through a filter of less than or equal to 0.22-microns.



CAUTION: Use only CardioQuip approved cleaners and disinfectants. Operation with unapproved agents may cause equipment damage.



1. Attach external hoses with a loopback connector for main circuit and CPG circuit (if so equipped) and put approximately six inches of sterile water or water that has been passed through a filter of less than or equal to 0.22-microns in the water tank.
2. With the front panel mains power switch turned off, plug the power connector into a dedicated "hospital grade" AC power outlet. The outlet should match the voltage, frequency and capacity listed on the MCH nameplate.
3. Turn on the mains power switch for the MCH. Ensure that the unit runs through a successful system test.
4. Touch the **Prime** button to initiate the priming sequence. The pump should turn on at full speed, and the valve should switch from COOLING to RECIRC approximately every ten seconds (check for ten-second bursts of water flow in the water tank).



5. After priming, ensure the water level in the water tank does not drop below four inches by adding sterile water or water that has been passed through a filter of less than or equal to 0.22-microns as necessary.
6. Add the selected cleaning chemical to the water tank at the manufacturer's recommended rates (see chart above for recommendations).
7. Run the MCH through five (5) standard priming cycles, or one extended priming cycle, to fully mix and circulate the cleaning chemical (10 minutes total). At some point during this step, set the recirculation valve (if so equipped) to INTERNAL for at least 10-15 seconds, to ensure that disinfectant reaches all sections of the internal plumbing.
8. Scrub the water tank, outlet screens, and Turbonozzle (if so equipped) with a nylon brush. It is imperative that the tank, screens, and Turbonozzle be thoroughly cleaned to ensure disinfection. The screens may be unscrewed and removed to assist in cleaning. Be sure to replace the screens before operating the MCH.



9. Turn off the mains power switch and drain the unit completely. **[MCH-1000(i):** open the system and tank drain valves, **MCH-1000(m):** Attach the system drain, p/n MCH-11DRN]. With the drain valves open, add sterile water or water that has been passed through a filter of less than or equal to 0.22-microns to flush the device until the chemicals are absent.



10. Close the drain valves and fill the water tank to maximum level with sterile water or water that has been passed through a filter of less than or equal to 0.22-microns. Turn on the mains power switch and run the MCH through a priming cycle to flush residual cleaning chemical from the system.
11. Turn off the mains power switch, and drain the system completely. If necessary, repeat the flushing sequence until all cleaning chemical is removed from the system.
12. With a nylon brush, clean the fan guard and air intake grille on the underside of the unit. All debris should be removed so that air flow is not impeded.
13. Inspect all plastic tubing on the hose kits. Any tubing that is clouded and/or has lost its flexibility should be replaced. To ensure proper function, exterior tubing must be replaced every 2 years regardless of condition. Replacement involves the detachment of the current hose and attachment of new hoses as outlined in the Maintenance section of this manual.
14. Internal tubing inspection: Instruct a qualified serviced personnel to unplug the unit and remove the side panel (see Fig.1) from the device. Visually inspect the clear internal tubing. If the tubing does not appear clouded or discolored, reattach the side panel.

Fig. 1 Removing Side Panels
Only remove the screws
highlighted in red:

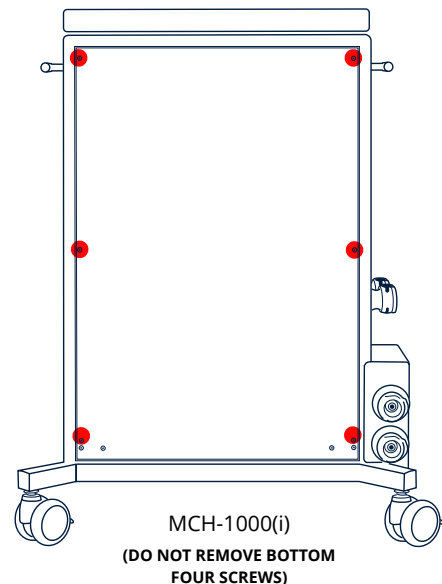
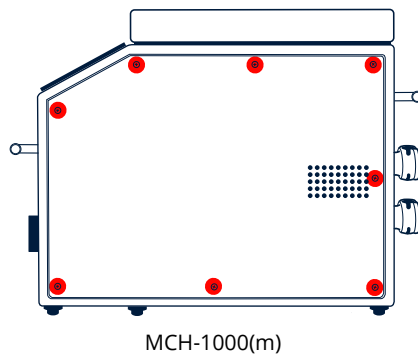

15. Perform the procedure listed under **After Every Use**. The system can now be returned to use or stored. Always store the system drained and dry.



WARNING: Electric shock hazard. Access panels should be removed only by qualified service personnel.



WARNING: If the tubing appears cloudy or discolored during the internal tubing inspection, immediately remove the device from service and contact **CardioQuip Customer Service** for details regarding servicing assistance.

Annual Maintenance

The MCH shall receive a complete preventive maintenance service check by an authorized CardioQuip service technician every 12 months. **CardioCare** annual preventive maintenance service is available for purchase at www.cardioquip.com/cardiocare.

Exterior tubing from the hose kits must be replaced every 2 years regardless of condition. Instructions for replacement can be found in the **Replacing External Tubing** section below.

Replacing External Tubing

Hospital-approved qualified service personnel may replace external tubing.

To replace external tubing:

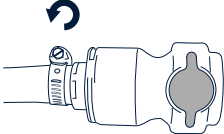
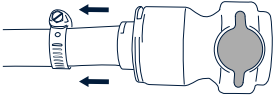
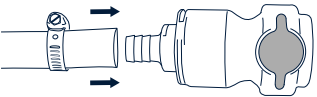
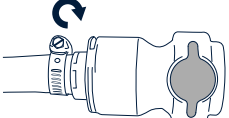
-  1. Unscrew the clamp securing the external tubing to the connector's hose barb with a flathead screwdriver or 1/4" hex drive.
-  2. Pull the tubing off of the connector.
-  3. Place the clamp over the edge of the new tubing before pushing the new tubing onto the connector's hose barb.
-  4. Screw the clamp into place with a flathead screwdriver or 1/4" hex drive to create a secure attachment. Repeat the same process with the other end of the tubing.

Disposal Procedures

Dispose of water drained from the MCH using a standard facility, floor, or greywater drain. Prior to disposing of the MCH itself (via sale, transfer, recycling, etc.), the **Quarterly Maintenance Procedure** should be performed and the MCH prepared for storage. Internal components of the MCH and its modules may contain trace amounts of lead or other toxic substances. When discarding the MCH or any of its modules, consult local regulations regarding the disposal of used electronics and medical equipment.

TROUBLESHOOTING

Symptom	Possible Cause	Solution
MCH will not turn on	Unplugged	Plug into a dedicated "hospital grade" 20A receptacle.
	No electric power at receptacle	Contact hospital maintenance personnel to check electrical outlets and power source.
	Internal wiring continuity	Have qualified service personnel inspect the internal wiring for loose connections.
	Mains power switch (integral circuit breaker) tripped	Reset the system's circuit breaker by turning the mains power switch off. Wait 1 minute, then turn the mains power switch on. If the breaker immediately trips, have qualified service personnel check for a direct short.
	Faulty mains power switch	Contact CardioQuip Service.
	Faulty temperature control circuitry	Contact CardioQuip Service.
System will not operate, but the touchscreen display is on	Internal wiring continuity	Have qualified service personnel check for an open in the DC Power Supply input wiring.
Main power switch lights up, but touchscreen display is off and system will not operate.	Disconnected DC Power Supply, or other loose internal wiring	Have qualified service personnel inspect the internal wiring for disconnected plugs or loose wire connections.
	Faulty DC Power Supply	Contact CardioQuip Service.
No circulation on main water connections	Pump not activated	Place system in RUN mode to activate the pump.
	Internal Recirculation Valve set to INTERNAL or OFF	Adjust Internal Recirculation Valve to NORMAL position.
	Blockage in water tank	Clean mesh strainers at the bottom of the water tank with a nylon brush.
	Blockage in external tubing	Inspect the external tubing for closed valves, kinks, bends or other blockage.
	Pump wiring fault	Have qualified service personnel inspect the internal wiring for loose connections.
	Faulty pump or pump circuitry	Contact CardioQuip Service.

Symptom	Possible Cause	Solution
No circulation on blanket water connection	No circulation on main water connections	See "No circulation on main water connections"
	Disengaged quick-disconnect coupling	Check coupling for complete connection. Partial coupling does not open the two-way valve internal to the connector.
	Clogged quick-disconnect coupling or tubing	Remove external tubing, leaving the external coupling connected. Using compressed air, force the blockage out.
	Faulty quick disconnect coupler	Contact CardioQuip Service.
System water flow is inadequate	Pump not primed	Place system in PRIMING mode according to operating instructions.
	Blockage in water tank	Clean mesh strainers at the bottom of the water tank with a nylon brush.
	Blockage in plumbing circuit	Have qualified service personnel inspect the internal tubing for kinks, bends or other blockage.
	Faulty pump or pump circuitry	Contact CardioQuip Service.
System will not cool	Inadequate ice supply	Add ice made from sterile water or water that has been passed through a filter of less than or equal to 0.22-microns to the water tank. 
	Inadequate water flow	See "System water flow is inadequate"
	No water flow at main water output	See "No circulation on main water connections"
Water does not flow through water tank	Blockage in plumbing circuit	Have qualified service personnel inspect the internal tubing for kinks, bends or other blockage.
	Internal wiring continuity	Have qualified service personnel check for an open in the valve input wiring.
	Valve solenoid seizure	Have qualified service personnel inspect and lubricate the valve solenoid.
	Faulty valve or valve circuitry	Contact CardioQuip Service.

Symptom	Possible Cause	Solution
System will not heat	Blockage in plumbing circuit	Have qualified service personnel inspect the internal tubing for kinks, bends or other blockage.
	Internal wiring continuity	Have qualified service personnel check for an open in the Heater input wiring.
	Faulty heater or heater circuitry	Contact CardioQuip Service.
System goes into an overtemperature condition	Blockage in plumbing circuit	Have qualified service personnel inspect the internal tubing for kinks, bends or other blockage.
	Faulty temperature control circuitry	Contact CardioQuip Service.
	Faulty heater or heater circuitry	Contact CardioQuip Service.
Cabinet Fan is not operational	Internal wiring continuity	Have qualified service personnel inspect the fan circuitry located behind the side panel.
	Blockage in fan assembly	Have qualified service personnel inspect the fan assembly for debris. The fan should be closely inspected for damage if debris is found.
	Faulty fan	Contact CardioQuip Service.
	Faulty DC power supply	Contact CardioQuip Service.
Line Isolation Monitor (LIM) alarm or error	LIM is not rated for the power requirements and/or power factor of the MCH.	Contact the LIM vendor.
	Excessive leakage current from the MCH	Contact CardioQuip Service.
Cloudy or discolored hoses	Device may be contaminated or exterior tubing may have undergone physical changes.	Immediately remove the device from service and contact CardioQuip Customer Service regarding servicing assistance.

If the above table does not address the problem, please contact CardioQuip Service for assistance. Wiring Schematics available upon request.

www.cardioquip.com/service